

# MULTIMODULO H27 Technical sheet

## 1. DESCRIPTION

Modular formwork made of recycled PP for ventilated foundations and for the creation of a physical barrier between the ground and the building.



## 2. TECHNICAL REFERENCES

Material	-	Recycled polypropylene (PP) 80-90%
	-	Minerals 0-10%
	-	Recycled polyethylene (PE) 10%
Percentage of recycled material	%	100
Color	-	Black
Dimensions*	cm	71x71x H27
Weight	kg	2.14 (± 10%)
Concrete consumption up to the formwork's satin**	m <sup>3</sup> /m <sup>2</sup>	0.035
Installations passage	mm	A Ø40mm B Ø200mm C Ø110mm
Supporting surface of the pillar	cm <sup>2</sup>	68.05
Installation time	m <sup>2</sup> /h/worker	100
Place of production	-	Italy

\* in consideration of the recycled material, the measures should be evaluated with a tolerance of ± 1,5%

\*\* The volume is subject to changes depending on the casting conditions and material tolerances

## 3. LOAD CHART

LOAD (Kg/m <sup>2</sup> )	Slab THICKNESS (cm)	REINFORCEMENT (mm)	Lean concrete thickness (cm)	Gravel thickness (cm)	Ground pressure (Kg/cm <sup>2</sup> )
500	5	Ø5 / 25x25	5		0,21
1,000	5	Ø6 / 20x20	5		0,41
2,500	5	Ø6 / 20x20	5		1,03
5,000	5	Ø8 / 20x20	10		0,85
10,000	6	Ø8 / 20x20	5	15	1,07
>10,000	To be assessed on a case-by-case basis by consulting the Geoplast Technical Office				

\* It is the designer's responsibility to assess that the installation plan is able to guarantee the specified pressures

#### 4. TECHNICAL DRAWINGS

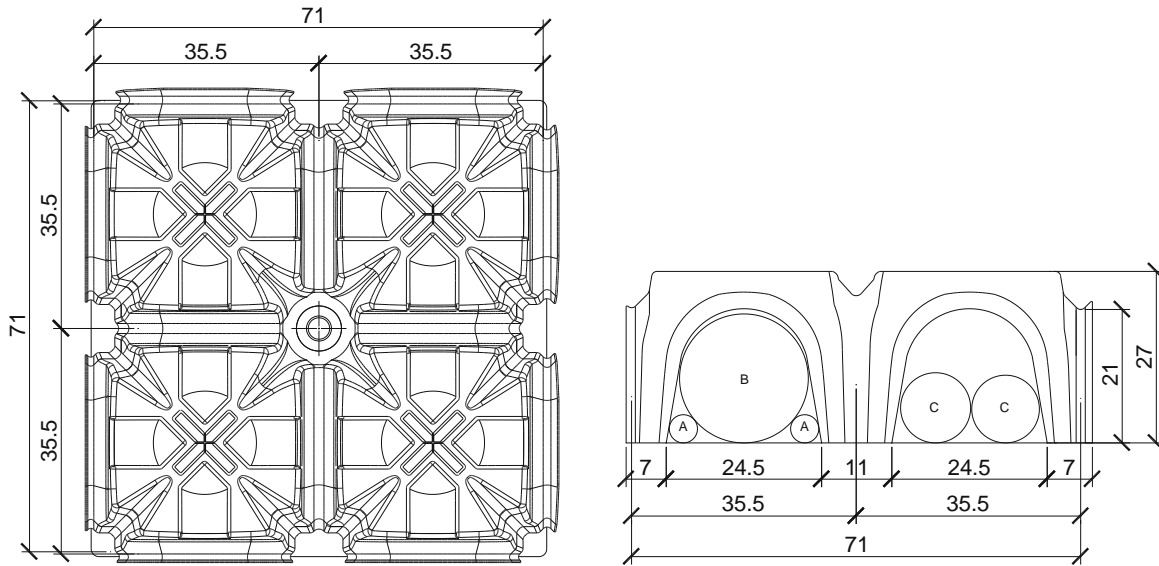

#### 5. PACKAGING AND TRANSPORT

Product code	-	EMODULO7127
Packing Size	cm	151 x 151 x H235
Type of packaging	-	Stacked and wrapped in plastic film
Quantity per pallet	pcs	360
Surface area per pallet	m <sup>2</sup>	180
Package gross weight	kg	772

#### 6. INSTALLATION METHOD

The Multimodulo installation is carried out by placing the formwork from right to left and from top to bottom, always keeping the arrow printed upwards. It is essential to check the correct fitting of the feet.

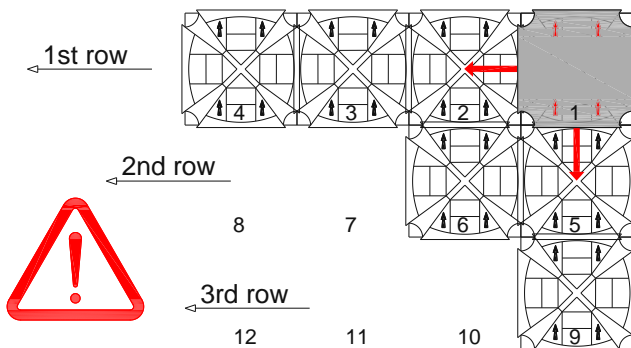

*Before starting to install the elements, we recommend that you consult Geoplast® project tables to position the elements appropriately. For a correct installation, in compliance with safety regulations, please refer to the installation manual.*

# GEOBLOCK H27 Technical sheet

## 1. DESCRIPTION

Adjustable extension for the Multimodulo formwork for the realization of ventilated crawl spaces and foundation beams in a single casting.



## 2. REFERENCE DIMENSIONS

Height (H)	cm	22
Net width (ai)	cm	26
Net length (li)	cm	30
Width (ae)	cm	32
Length (le)	cm	33
Step	cm	3.5
Maximum extension	cm	24.5
Weight	kg	0.58

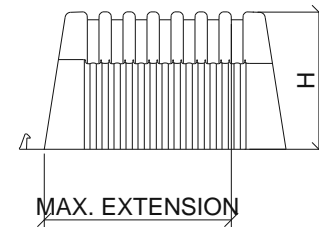
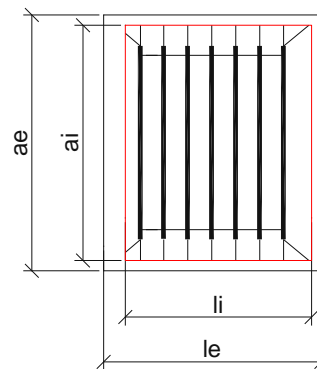

## 3. PACKAGING AND TRANSPORT

Product code	-	EMMGBLO0027
Packing Size	cm	120 x 102 x H130
Type of packaging	-	Stacked in pallets
Quantity per pallet	pcs	500
Pallet weight	kg	305

# CARTONPLASTICO H27 Technical sheet

## 1. DESCRIPTION

Side closure for Multimodulo formwork for the realization of ventilated under-floor cavity and foundation beams in a single casting.



## 2. REFERENCE DIMENSIONS

Height (H)	cm	27+5
Thickness	cm	0.4
Length	cm	100
Weight	kg	0.32

## 3. PACKAGING AND TRANSPORT

Product code	-	EMMFGET0027
--------------	---	-------------