

Technical data sheet NEW NAUTILUS EVO 28

1. DESCRIPTION

Recycled PP formwork for the construction of light bi-directional slabs with flat intrados and large spans.



2. TECHNICAL SPECIFICATIONS

| | | |
|----------------------------------------------|--------------------------|------------------------------------|
| Material | - | Recycled polypropylene (PP) 97-99% |
| | - | Additives 1-3% |
| Percentage of recycled material | % | 100 |
| Colour | - | Black |
| Dimensions * | cm | 52x52x H28 |
| Weight | kg | 1.55 (± 10%) |
| Lower spacer height | cm | 0-4-5-6-7-8-9-10 |
| Upper spacer height | cm | 0.8 |
| Formwork volume | m ³ /pz | 0.053 |
| Installation time (just plastic component)** | m ² /h/worker | 35 |
| Punching resistance | daN | 190 |
| Fire resistance*** | - | REI 180 |
| Place of production | - | Italy |

* in consideration of the recycled material, the measures should be evaluated with a tolerance of ± 1,5%

** The laying times of the complete slab are subject to considerable variations depending on the amount of reinforcement and the working conditions of the workers.

***value referred to the UNI EN 1365-2 2002 and 1363 2012, carried out with standard sample with dimensions 2.98 x 7.33 m, thickness 28 cm and subjected to lasts solicitation moment of at least REI 180' with a minimum reinforcement covering of 30mm (EOTA).

3. CONCRETE CONSUMPTION CHART

| Lower spacer height p | Higher spacer height d | Beam T | Interax i | Incidence of formworks | Concrete consumption up to the formwork's satin | Formwork volume | Concrete saving up to the formwork's satin* |
|--------------------------|------------------------------|-----------|--------------|---------------------------|-------------------------------------------------------|--------------------|---------------------------------------------------|
| [cm] | [cm] | [cm] | [cm] | [pz/m ²] | [m ³ /m ²] | [m ³] | [m ³ /m ²] |
| 0-4-5-6-7-8-9-10 | 0,8 | 12 | 64 | 2,44 | 0.151 | 0,053 | 0,129 |
| 0-4-5-6-7-8-9-10 | 0,8 | 14 | 66 | 2,30 | 0.158 | 0,053 | 0,122 |
| 0-4-5-6-7-8-9-10 | 0,8 | 16 | 68 | 2,16 | 0.166 | 0,053 | 0,114 |
| 0-4-5-6-7-8-9-10 | 0,8 | 18 | 70 | 2,16 | 0.172 | 0,053 | 0,108 |
| 0-4-5-6-7-8-9-10 | 0,8 | 20 | 72 | 1,93 | 0.178 | 0,053 | 0,102 |

* may also be taken into account the concrete saving due to the lower weight of the building

4. TECHNICAL DRAWINGS

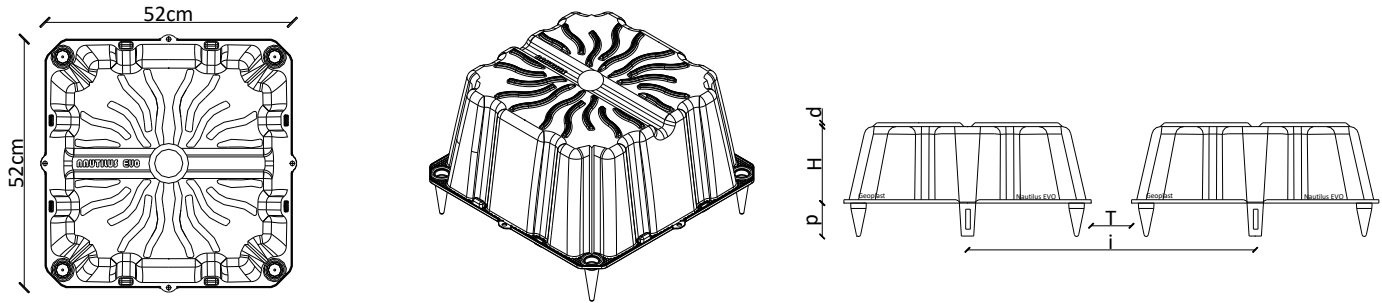

5. TECHNICAL SUPPORT

Geoplast Technical Unit is at the disposal of architects and engineers to offer the required assistance during the implementation of a project. From the statistical calculations to the working drawings.

- **FEASIBILITY STUDY:** Technical Analysis of the project which includes the choice of the most suitable product.
- **PRELIMINARY DESIGN:** Static analysis and preparation of documentation attesting to the reliability of the performance of the proposed system.
- **EXECUTIVE DESIGN AND ON-SITE ASSISTANCE:** Support of specialized designers. A detailed analysis with installation diagrams and/or on-site support can be provided on request.

6. PACKAGING AND TRANSPORT

| | | |
|------------------------|----|----------------------------------------------------------------------------|
| Product code | - | ENNAESH28XX |
| Code composition | - | 1 pcs NEW NAUTILUS EVO with spacers included, 2 lateral spacers 10-20cm |
| Lower spacer height | cm | 0-4-5-6-7-8-9-10 |
| Packaging size | cm | 110 x 120 x H250 |
| Type of packaging | - | Stacked and wrapped in plastic film on pallet |
| Quantity per pallet | pz | 400 |
| Package gross weight * | kg | 637 |

* weight may change by (\pm 10%)

Technical data sheet NAUTILUS CAP

1. DESCRIPTION

Closing cap, NAUTILUS CAP, for NEW NAUTILUS EVO.



2. TECHNICAL SPECIFICATIONS

| | | |
|---------------------|----|------------------------------------|
| Material | - | Recycled polypropylene (PP) 97-99% |
| | | Additives 1-3% |
| Dimensions | cm | 52 x 52 x 0.35 |
| Weight | kg | 0.49 |
| Place of production | - | Italy |

3. PACKAGING AND TRANSPORT

| | | |
|----------------------|----|------------------|
| Product code | - | ENAUTAP0000 |
| Packaging size | cm | 110 x 110 x H110 |
| Quantity per pallet | pz | 800 |
| Package gross weight | kg | 409 |

4. TECHNICAL DRAWINGS

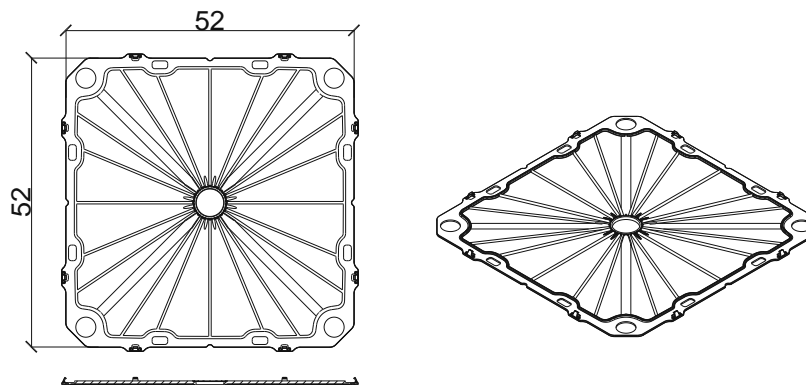

*Accessory not included in standard supply