



WATER SOLUTIONS

RAINWATER MANAGEMENT SYSTEMS



DRENING



DRAINPANEL



NEW ELEVATOR TANK

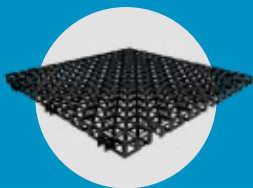

GEOCELL



RESISTANCE



MODULARITY



EFFICIENCY

INDEX



DRENING

Plastic tunnel for rainwater infiltration and attenuation.

P. 4



DRAINPANEL

Stormwater inspectable modules for infiltration and attenuation.

P. 18

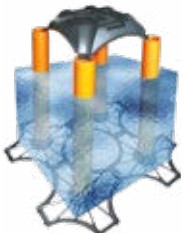

NEW ELEVATOR TANK

Permanent formwork for in situ cast concrete water storage systems.

P. 28

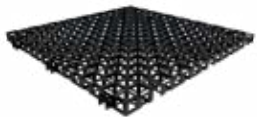
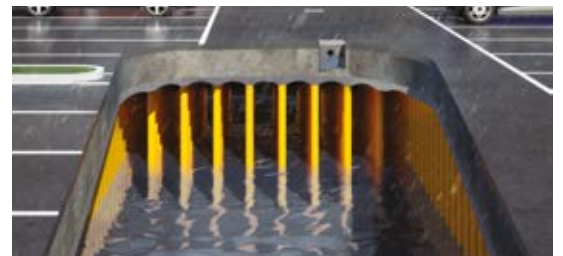

GEOCELL

Cellular structural drainage panel with high horizontal flow capacity.

P. 41



DESIGN & ASSISTANCE

FROM PREDIMENSIONING TO FINAL DRAWING

Geoplast Technical Unit is at the disposal of architects and engineers to offer the required assistance during the implementation of a project. From the statistical calculations to the working drawings.

FEASIBILITY ANALYSIS

Technical Analysis of the project which includes the choice of the most suitable Geoplast's solution, material and manpower estimates and cost analysis.



TECHNICAL ANALYSIS

Structural Analysis and writing of all the documentation that tests the performance of the proposed systems.

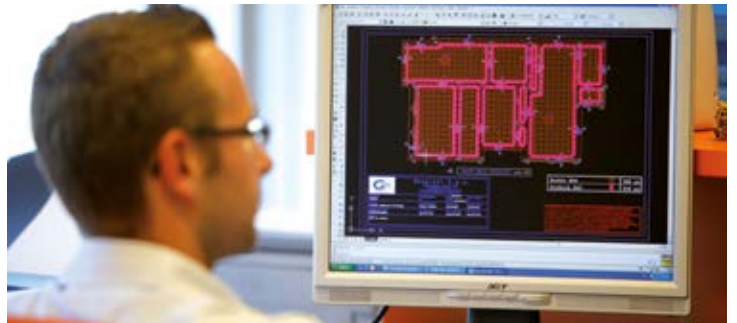

EXECUTIVE DESIGN

Support by design professionals. The in-depth analysis together with the formwork positioning plan and the related accessories can be supplied on request.



ON-SITE ASSISTANCE

When necessary, Geoplast's technical unit can be present on-site and help the company during the installation stage.



To contact the technical unit : Tel. +39 049 949 0289 - Area Managers Italy Acqua@Geoplast.it – Export Area Managers Export@Geoplast.it
To download the updated technical sheets, the support material, new images and new case studies, visit our website:

GeoplastGlobal.com

DRENING



- ✓ REDUCED DIGGING
- ✓ RESISTANT
- ✓ LIGHT

PLASTIC TUNNEL FOR RAINWATER INFILTRATION AND ATTENUATION



DRENING ADVANTAGES



High resistance modular system for the creation of retention ponds and high capacity accumulation basins.

LIGHT



DRENING weighs only 10 kg and can be moved manually without the need of mechanical devices.

FAST



The lightness and simplicity of installation make the operations quick and safe.

REDUCED DIGGING



DRENING permits a shallow and non-invasive intervention, ideal in areas with groundwater.

RESISTANT



The arch structure ensures DRENING a high mechanical strength. The system can be installed under heavy trafficked areas.

CAPACITY



Each DRENING contains up to 310 liters of water per m² of surface.

DRAINAGE



The large dispersant surface of DRENING guarantees a quick and efficient dispersion of the accumulated water.

DRENING THE SOLUTION



DRENING is a modular element in HDPE. It is designed for the creation of underground retention ponds used for “in-situ” rainwater management. Depending on the type of installation, DRENING can be used to facilitate subsoil drainage in order to prevent surface overflowing while refilling the aquifers, but it is also useful to reuse of collected water to save water resources. DRENING can be used also for sewage disposal from settlements which are not connected to the sewer system. The material and the structure of DRENING are particularly designed for the creation of high capacity systems which can be placed under high traffic areas with a minimum digging depth, for minimally invasive interventions.

DRAINAGE OF PARKING LOTS

WATER DRAINAGE IN PUBLIC AREAS

WATER DISPOSAL IN INDUSTRIAL AREAS

DRAINAGE OF ROAD INFRASTRUCTURES

PHYTOPURIFICATION

RECOVERY AND REUSE OF RAINWATER

WASTEWATER



DRENING TECHNICAL DATA

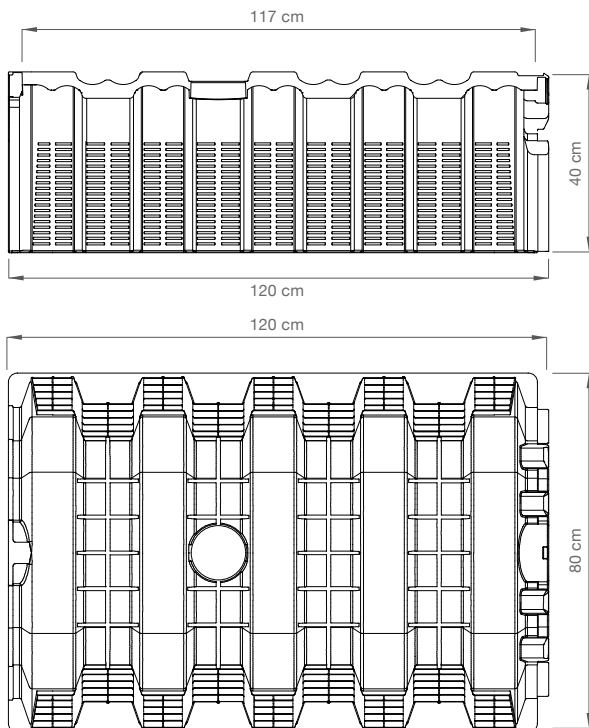

DRENING

Actual size (cm)	120 x 80 x 40
Installed product's length (cm)	117
Material	HD PE
Weight (kg)	9,52
Capacity (l)	310
Side infiltration surface (cm ²)	2.800
Packaging size (cm)	120 x 80 x 230
No. pieces per pallet	40

MAXIMUM LOAD WITH SUITABLE
FINISHED STRATIGRAPHY:
up to CLASS SLW60



CAP

Actual size (cm)	70 x 40
Thickness (cm)	6
Material	HD PE
Weight (kg)	1.81
No. pieces per pallet	according to the project requirements

THE CLOSING CAP



This cap has to be placed at the beginning and at the end of each line of elements in order to close the system.

It is already designed to be drilled in order to insert the pipes (diameters from 60 to 320 mm).

DRENING THE CONCEPT

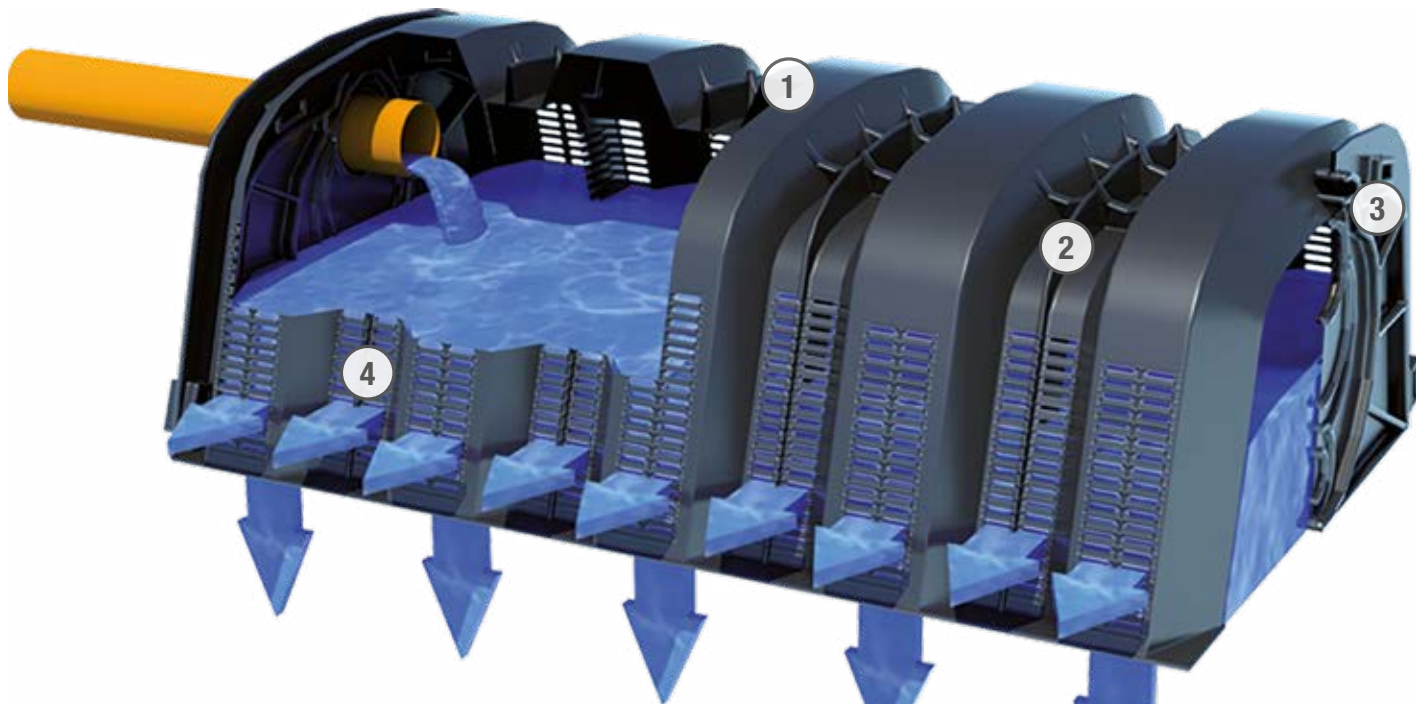

① Upper part designed for the insertion of a venting system or an inspection conduct.



② Reinforced arch structure to guarantee the resistance to heavy loads.



③ Double overlapping locking system that guarantees an interlocking installation and a stable connection between the elements.



④ Completely opened base with side holes, with a permeable surface of 12.400 cm² per element.

RESTORATION OF THE HYDROLOGICAL BALANCE

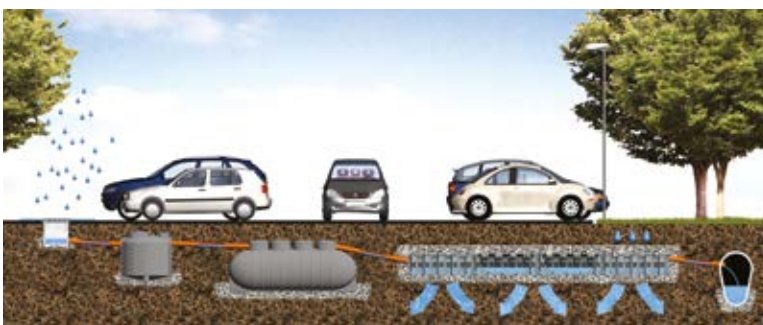

DRENING is not only a flood prevention measure, but as it facilitates water infiltration in the subsoil, it is also useful to refill the aquifers, one of the main water supply sources usually exploited. In this way, the natural water balance that is otherwise subverted by the waterproofing of the subsoil, remains intact.

ON SITE INSTALLATION

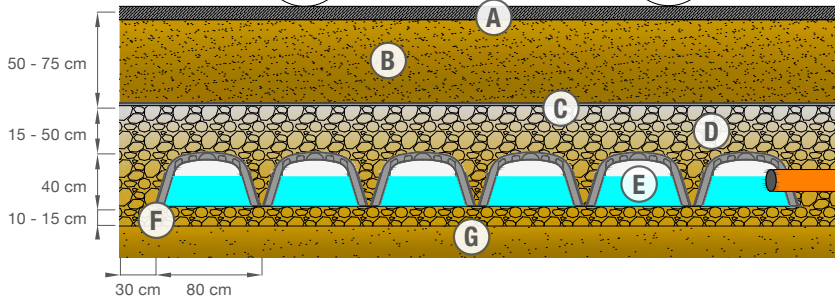
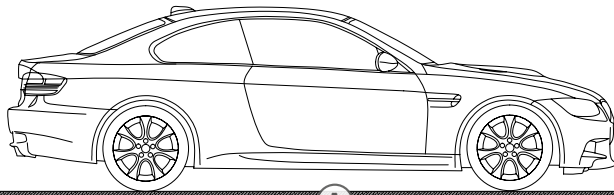

LEGEND

- (A) Road finishing
- (B) Covering
- (C) Geotextile
- (D) Washed gravel 20/40 mm
- (E) DRENING
- (F) Gravel (draining) Waterproof membran (accumulation)
- (G) Existing ground



① GRAVEL LAYING

Ground excavation and collocation of a layer of washed gravel of about 20-40 mm thickness 10-15 cm.



② INSTALLATION

Manual installation of DRENING (estimated speed: 1 element per minute).



③ CONNECTIONS

Closing of the system with the specific caps and insertion of the power source pipes and the overflow ones (if required by the project).



④ COVERING

Backfill of at least 30 cm and covering with washed gravel 20-40 mm for a minimum thickness of about 15 cm (this can change depending on the provided stratigraphy).



⑤ GEOTEXTILE

Place a geotextile all over the contact surface between the gravel and the natural ground.



⑥ FINISHING

Final stratigraphy (road infrastructure or green surface) as required by the project.

DRENING APPLICABLE LOADS

Depending on the applicable loads, the system must be provided with a minimal thickness for the covering of Draining chambers.

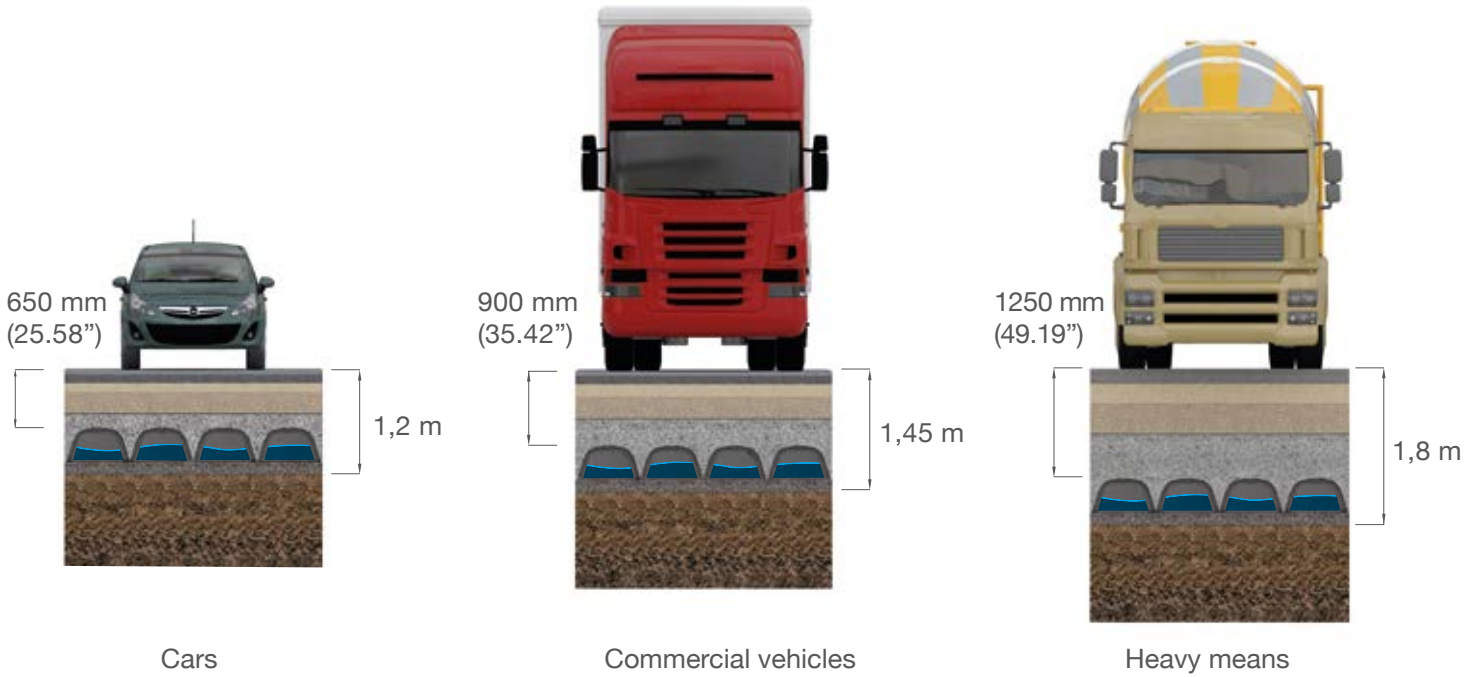

The recommended stratigraphies on the basis of the applied loads are available on www.geoplast.it. If a change in the following schemes is required, please contact Geoplast Spa.



DIMENSIONING PARAMETERS

REQUIRED DATA FOR THE RIGHT CALCULATION OF THE BASIN



RAINFALL

This data refers to a heavy yet short rainfall (30 minutes are recommended)



DRAINING SURFACE

Evaluation of the draining surface with application of the suitable flow coefficients.



LEGISLATION

Discharge limits, first rains treatment, return times to consider.



GROUND PERMEABILITY

Evaluation of the basin emptying times and the suitability of the positioning of the system.



APPLIED LOADS AND SELECTION OF THE INSTALLATION STRATIGRAPHY

Evaluation of the loads placed on the system for the selection of the installation stratigraphy. Depending on the chosen thickness of the gravel, the specific water storage capacity will also be evaluated.

EXAMPLE OF PRELIMINARY DIMENSIONING

PROJECT DATA

Draining surface	5.000 m ²	Amount of rainwater to dispose	225 m ³
Flow coefficient	1	Storage capacity per m ² of basin (considering the stratigraphy for 1st category loads)	0.51 m ³ /m ²
Rainfall (30' duration)	45 mm	Number of DRENING (minimum quantity of items to completely support the required volume)	440
Applied loads	1 ^a category	Surface occupied by the draining basin	422 m ²
Infiltration speed	10 ⁻⁴ m/s	Hydraulic residence time (required time for the emptying of the basin)	1.4 h

DRAINAGE OF CAR PARKS

DRENING is the ideal solution to deal with rainwater in car parks as it significantly reduces the water volume in the drainage system, facilitating the infiltration in the subsoil in order to prevent surface floods. The easy and fast installation allows to build also very large basins in a short time. In this way DRENING is a very competitive solution in comparison to other traditional drainage systems.



WATER DISPOSAL IN INDUSTRIAL AREAS

DRENING allows the construction of underground basins to dispose efficiently and rapidly the water flowing from loading and unloading areas or from the roofs of the warehouses. Thanks to its high resistance, DRENING can also be installed under high traffic areas, such as manoeuvring yards and truck parks. Moreover, the modularity of the product permits an excellent adaptation to the available surfaces.



DRAINAGE IN PUBLIC AREAS

DRENING is a solution with low environmental impact useful to prevent floods in the new urbanization areas while respecting the local legislations about the unloading of water into the sewage system. It guarantees excellent water drainage and allows in-situ water management, thus avoiding the inconveniences and safety issues of an open-air basin. Thanks to its modular structure, DRENING adapts to every available surface and guarantees minimally invasive intervention.



DRAINAGE OF ROAD INFRASTRUCTURES

DRENING can be used to build drainage systems such as dugouts near the roadside and retention basins in the roundabouts, that can be useful to eliminate rainwater and avoid traffic issues. Thanks to the compact volume and the fast installation, DRENING is easy to move in narrow areas like road construction sites. Furthermore, thanks to its high resistance, it can be installed in high traffic areas.



DRENING AND PHYTOPURIFICATION

DRENING can be used as a supporting element to the lower vegetated and permeable areas that can be found at the edge of the roads or car parks, where rainwater flows. Pollutants contained in road run-off water are thus removed through phytodepuration: clean rainwater then seeps into the subsoil, where it is stored in the underground basin and then disposed. In this way not only a large quantity of rainwater can be easily managed, but cleaner water is also returned to the environment.

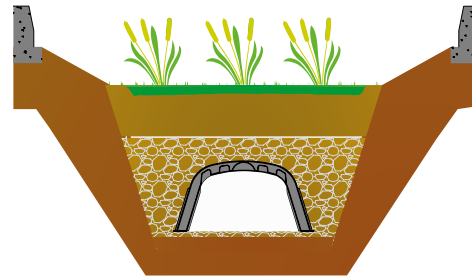

RECOVERY AND REUSE OF RAINWATER

Through the waterproofing of the excavation, in order to avoid leakage in the subsoil, DRENING can be used to create accumulation basins to collect and store rainwater that can be reused for irrigation. In this way not only drainage issues are solved, but also water can be saved and later reused in many different ways. DRENING chambers modularity and high capacity allow the creation of systems of any size in order to obtain good storage volumes.



DRENING REFLUE



DOMESTIC SEWAGE DISPOSAL RESPECTING THE ENVIRONMENT

DRENING can be used to dispose domestic wastewater through sub-irrigation following primary treatment. This is the ideal solution for residential areas which are not connected to the sewage system. Thanks to its large infiltration surface, DRENING guarantees fast and uniform infiltration in the subsoil. Moreover, it is possible to install ventilation ducts in the system in order to prevent bad smells and to return cleaner water to the environment. DRENING is also easier to clean and inspect in comparison with the micro-perforated pipe which is traditionally used.

LEGEND

- (A) Septic tank
- (B) Ventilation
- (C) DRENING
- (D) Infiltration
- (E) Laying in trench

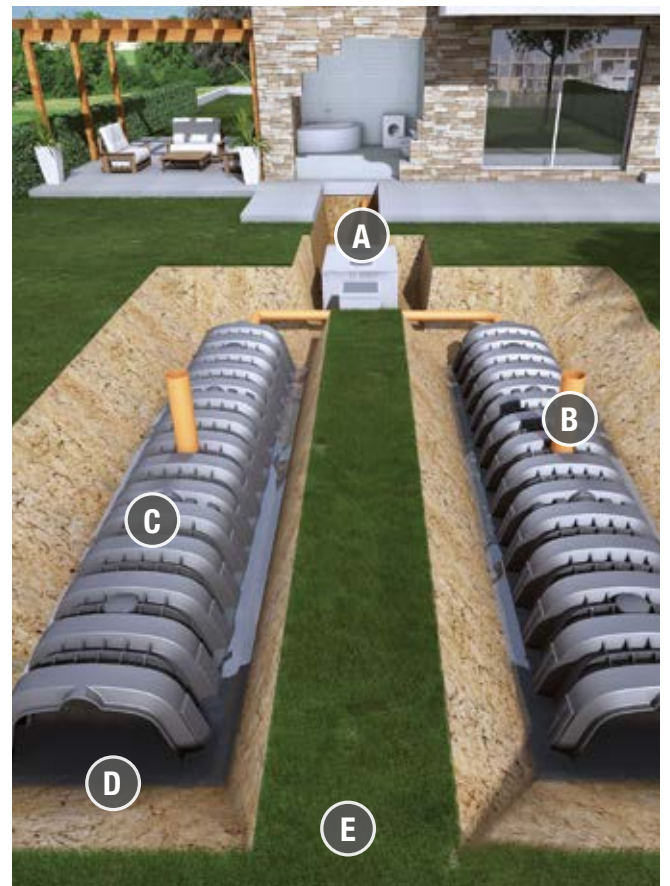

ON SITE INSTALLATION



① EXCAVATION
Excavation of a dugout 90 cm wide at the base.



② GRAVEL LAYER
Gravel layer of 20/40 mm (min. thickness 10 cm).



③ DRENING
Installation of DRENING chambers.



④ COVERING
Insertion of the supply and ventilation pipes. Cover with min. 15-20 cm of gravel 20/40 mm.



⑤ GEOTEXTILE
Place of the geotextile over the whole surface.



⑥ BACKFILL
Backfill until reaching the ground level.

THE VENTILATION

The ventilation of the system is fundamental to avoid the diffusion of smell and to improve the purification of wastewater. The lack of air causes the bacterial degradation of the organic compounds that can be found in the wastewater and produces foul smells.

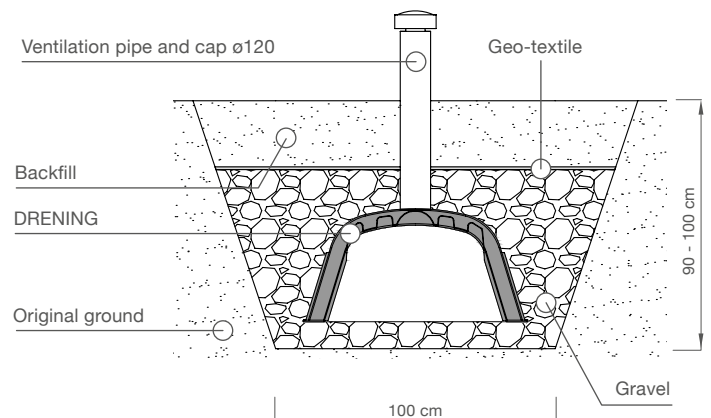

DRENING REFLUE SIZING PARAMETERS

Type of soil	No. Drening per equal environment*	Percolation volume (l)	Infiltration surface (cm ²)
Rough sand, stones, gravel or mixed	1	300	12400
Fine sand	1.5	450	18600
Sand and gravel or stones with stilt	2	600	24800
Clay or stilt with a lot of sand or stones	3	900	37200
Clay or stilt with few sand or stones	6	1800	74400
Waterproof compact clay	Not suitable	-	-

*Parameter of equivalence of the polluting load, usually equal to BOD of 60 g of oxygen per day.

The number of DRENING elements for a wastewater disposal system must be calculated on the type of soil within the area where it will be placed, and the amount of equivalent inhabitants. To obtain this data it is necessary to multiply the number of inhabitants to the multiplicative coefficient concerning the type of soil, as in the table above

TYPICAL INSTALLATION SCHEME

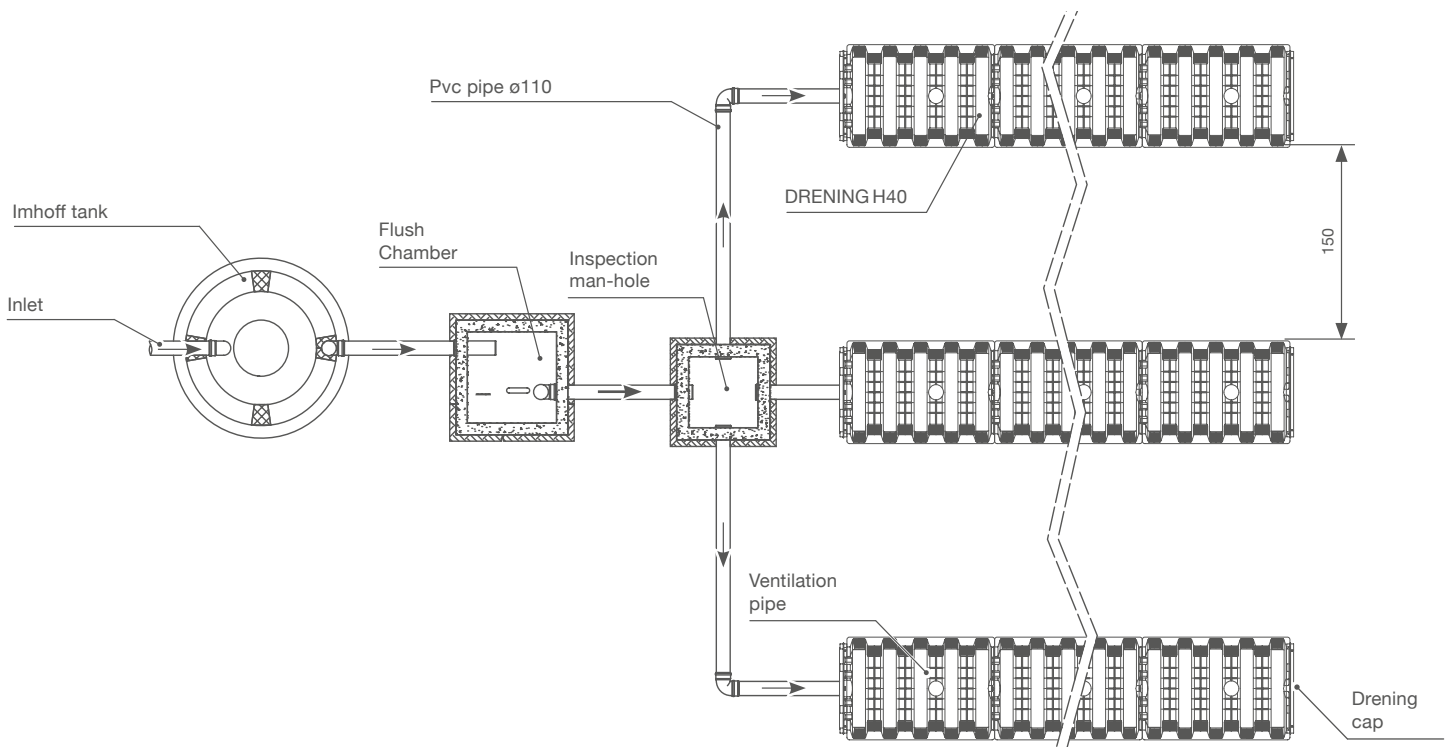

DRAIN PANEL



STORMWATER INSPECTABLE MODULES FOR INFILTRATION AND ATTENUATION



DRAINPANEL ADVANTAGES



Stormwater inspectable modules for infiltration and attenuation.

LIGHT



Weighing less than 13 kg DRAINPANEL can be manually handled without using mechanical devices.

FAST



The lightness and simplicity of installation makes the basin's creation fast and safe.

STACKABLE



DRAINPANEL elements are easy to stack during the packaging, in order to obtain significantly reduced storage volumes in comparison to equivalent systems.

RESISTANT



The structure and the material give DRAINPANEL a high mechanical resistance, that allows its installation even under high trafficked areas.

CAPACITY



DRAINPANEL was designed to obtain a high void ratio, higher than a draining trench full of gravel.

OVERLAPPING



DRAINPANEL can be overlapped until the creation of a system that develops it self in depth, resistant to heavy loads.

DRAINPANEL THE SOLUTION

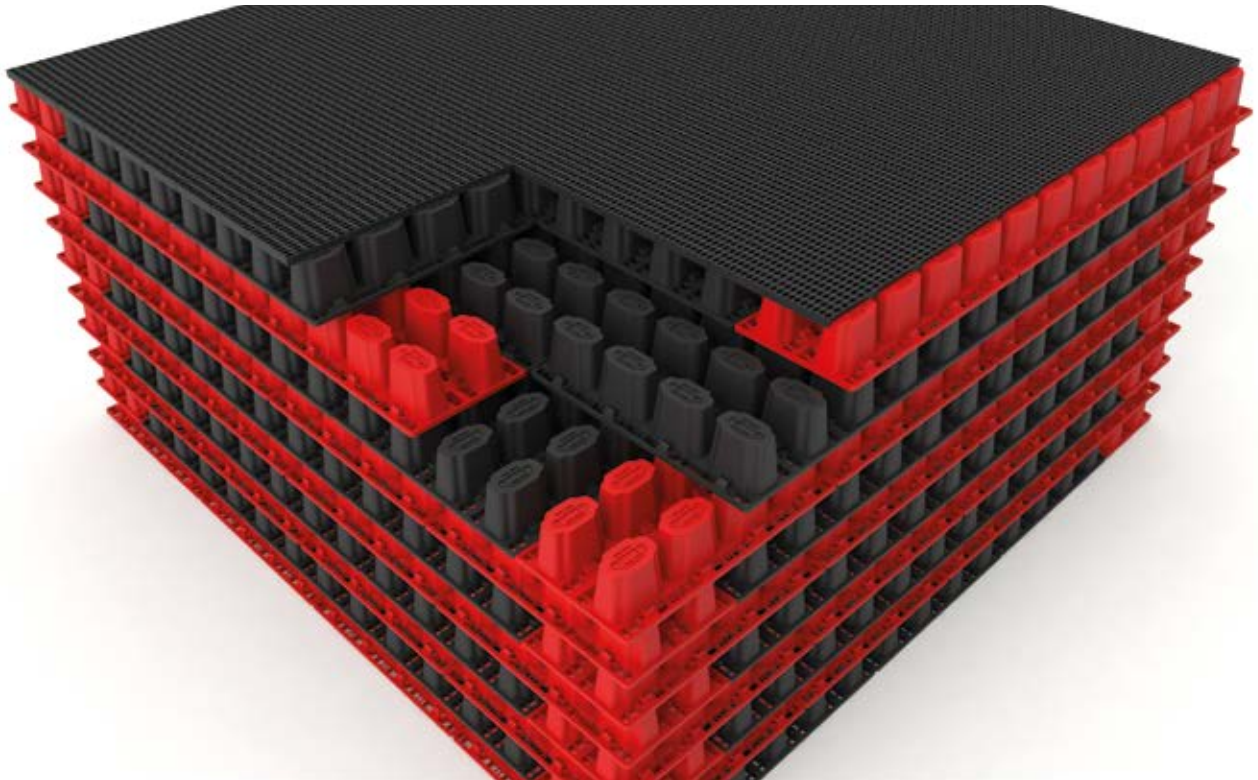

DRAINPANEL is a modular element in regenerated PP designed for the creation of underground stormwater management basins. DRAINPANEL contributes to the recharge of groundwater aquifers and can be used to create either a retention or an infiltration basin in order to subsequently reuse the water. When we use the system for infiltration, it has to be wrapped with the geo-textile, because it allows the drainage of the water in the ground. When, by contrast, the water needs to be held in the basin, the use of a waterproof geomembrane is recommended. The installation of the elements is dry, they are hooked and stacked together. Thanks to its high mechanical resistance, DRAINPANEL can be installed also under heavy trafficked areas because the basin can develop at greater depths under the ground.

INFILTRATION BASINS

LAMINATION TANKS

RECOVERY AND REUSE OF RAINWATER



DRAINPANEL TECHNICAL DATA

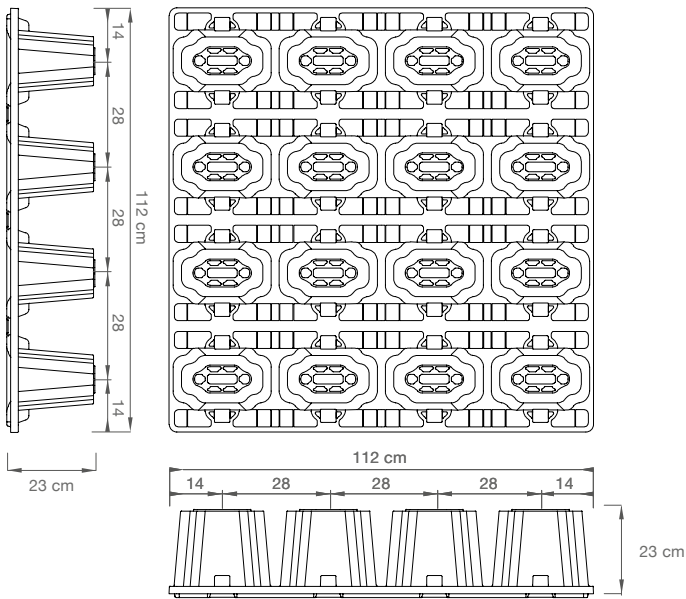

DRAINPANEL

Actual size (cm)	112 x 112 x 23
Installed product height (cm)	20
Material	PP
Weight (kg)	13,50
Storage volume (m ³)	0,25
Voids percentage	96%
Packaging size (cm)	112 x 112 x 250
No. pcs. per pallet	75

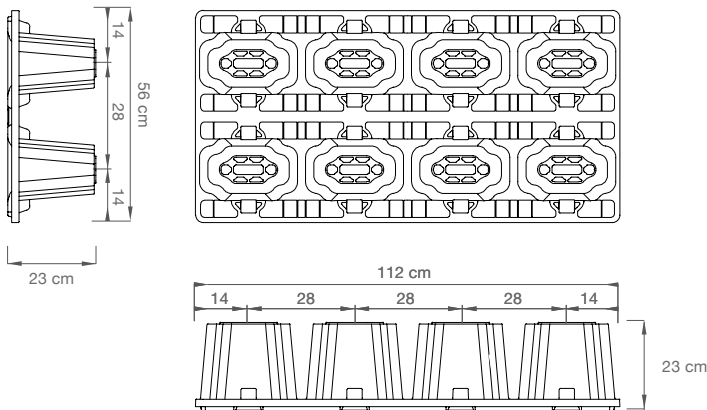

DP-HALF

Actual size (cm)	112 x 56 x 23
Installed product height (cm)	20
Material	PP
Weight (kg)	6,75
Storage volume (m ³)	0,125
Voids percentage	96%
Packaging size (cm)	112 x 112 x 250
No. pcs. per pallet	150

DRAINPANEL GRID

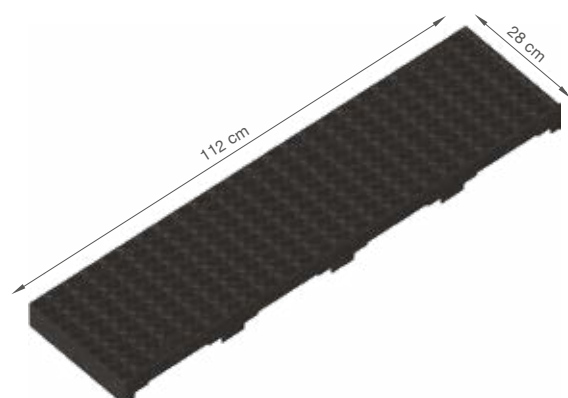

This element allows the upper closure of the system to facilitate the installation of the geo-textile and of the waterproof geomembrane.

Size: 112 x 28 cm
 Thickness: 3,8 cm
 Weight: 2,04 kg

DRAINPANEL THE CONCEPT

HIGH VOID RATIO

DRAINPANEL is an alternative to gravel systems, when creating trenches or rainwater draining areas. The structure of the panel guarantees a regular void ratio which is 3 times higher than the gravel one (the cone-shaped elements are hollowed inside and can be easily filled with water). In this way, a high storage capacity is guaranteed and the digging volume can be contained

VOID PERCENTAGE

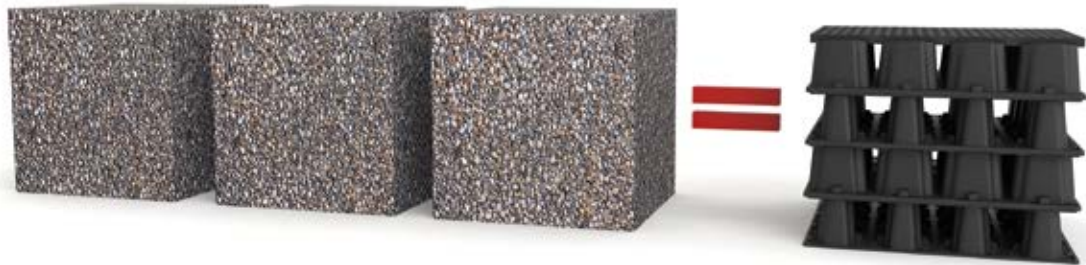
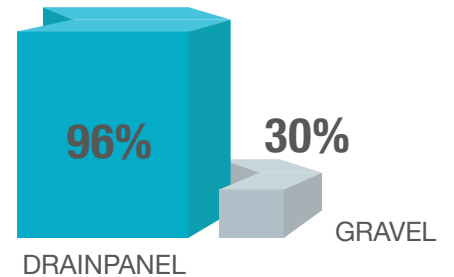

DRAINPANEL STORAGE AND TRANSPORT

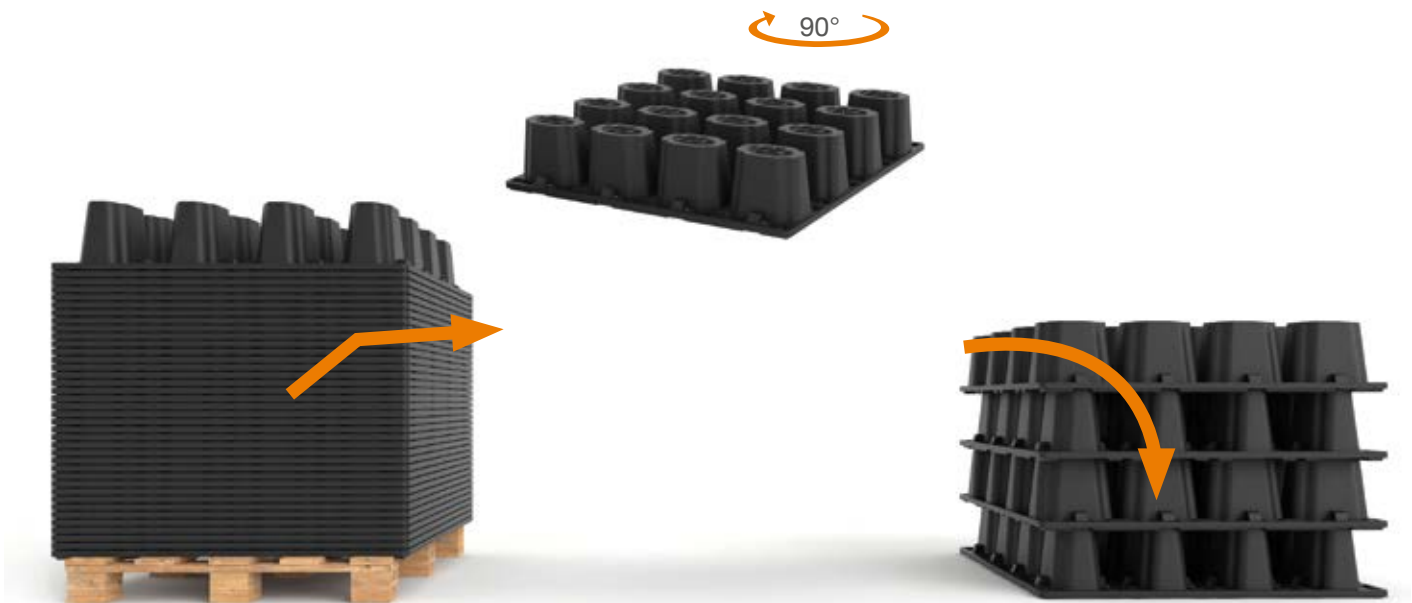

DRAINPANEL innovative design permits the easy stacking of the elements (the ones in the same direction) and the reduction of the space used for the storage and transport of the materials. It is also possible to create larger water retention volumes by stacking the elements in layers, oriented alternatively by 90 degrees.

TRANSPORT COMPARISON BETWEEN GRAVEL AND DRAINPANEL

A truck can transport approximately 25 pallets of DRAINPANEL (footprint of approx. 80 cbm.). The 25 pallets allow the installation of a basin with a capacity of 450 cbm. and considering that a truck which generally transports inerts can contain up to 20 cbm. of material per time, this is a great advantage in terms of logistics. By contrast, the transport of gravel usually requires 75 trucks.

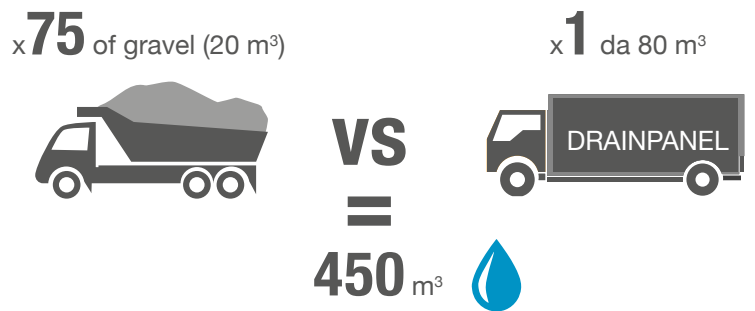

DIFFERENT USE ACCORDING TO THE COVERING

Depending on the type of geo-textile used, the structure of DRAINPANEL is ideal for the dispersion of water in the ground and also for the lamination or accumulation of water.

DISPERSION

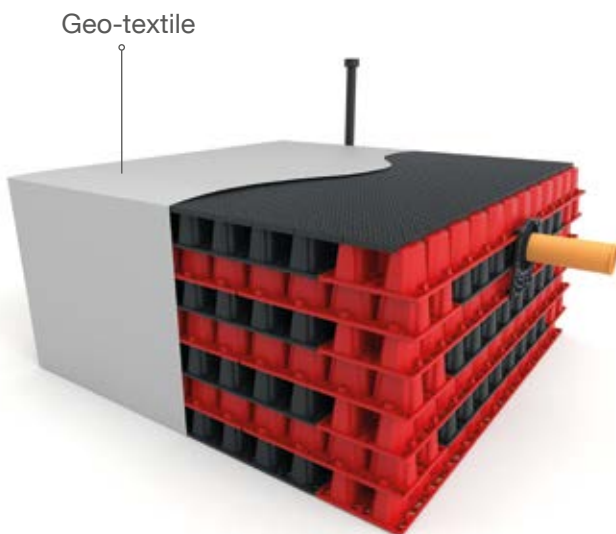

The geo-textile layer allows a correct water flowing and helps the water penetration into the ground.

ACCUMULATION

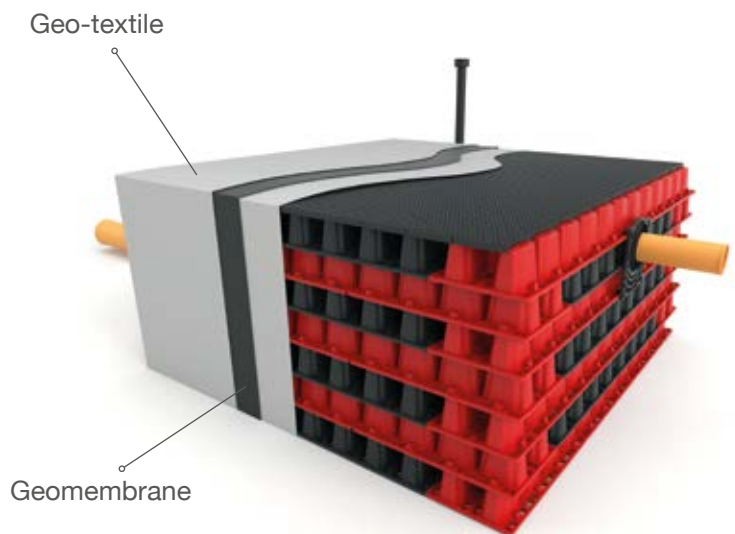

The waterproof membrane is covered by a geo-textile on the sides in order to retain the water in the structure.

ON-SITE INSTALLATION

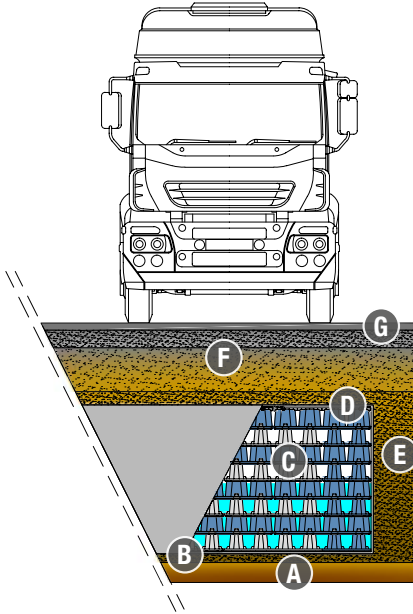

LEGEND

- Ⓐ Natural soil
- Ⓑ Bedding layer
- Ⓒ Drainpanel system
- Ⓓ Geo-textile or Geomembrane
- Ⓔ Backfill
- Ⓕ Covering layer
- Ⓖ Road finishing



① EXCAVATION

Dig the ground, on the basis of the design dimensions.



② PREPARATION

Coat a layer of gravel or sand in order to regulate the bottom of the excavation and place the geo-textile.



③ INSTALLATION

Place DRAINPANEL manually and place DRAIPANEL GRID over the last layer.



④ CONNECTIONS

Create the supplying and discharging ducts of the basin.



⑤ GEO-TEXTILE

Cover the sides of the plastic structure's upper part with the geo-textile.



⑥ FINISHING

Backfill the excavation and proceed with the creation of the road or of the green area.

DRAIN PANEL APPLICABLE LOADS

On the basis of the applied loads, the system should provide a minimal thickness to cover the structure.

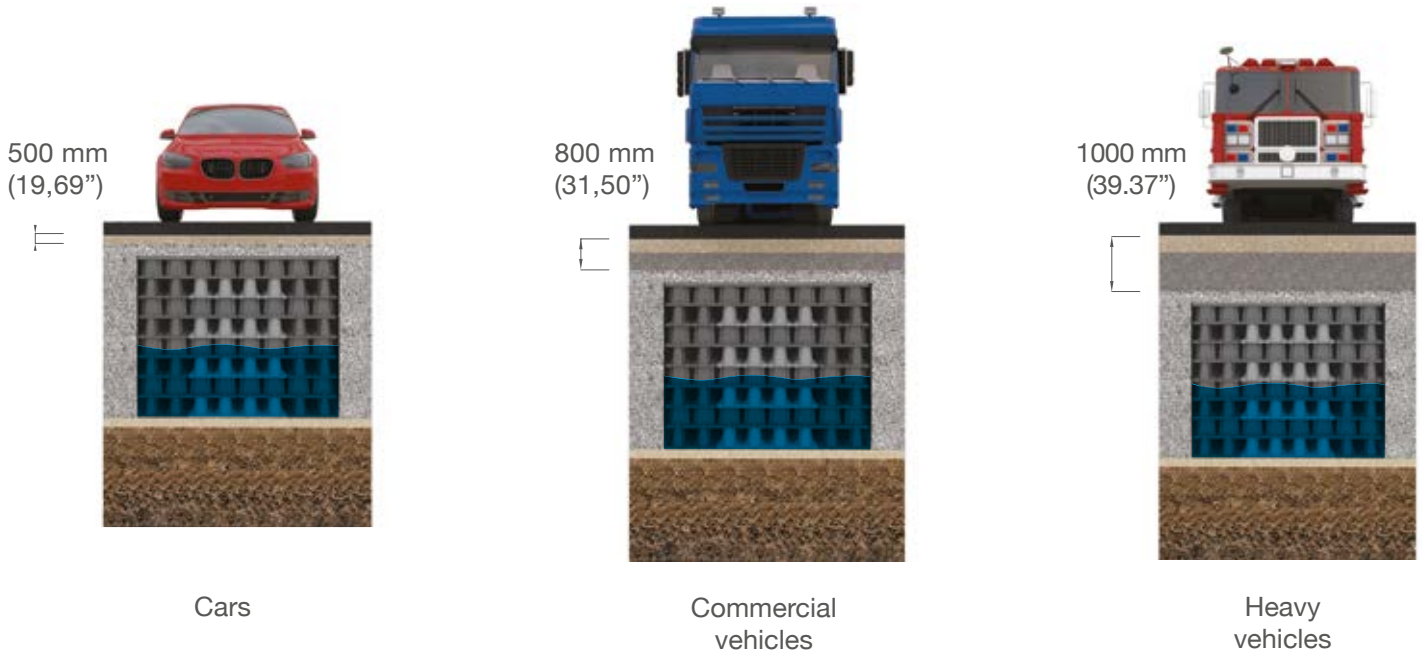

The thickness in the drawings is indicative, for more detailed info about thickness and layers number, contact Geoplast's technical unit.



DIMENSIONING PARAMETERS

REQUIRED DATA FOR THE RIGHT CALCULATION OF THE BASIN



RAINFALL

This data refers to a heavy yet short rainfall (30 minutes are recommended).



DRAINING SURFACE

Evaluation of the draining surface with application of the suitable flow coefficients.



LEGISLATION

Discharge limits, first rains treatment, return time to consider.



GROUND PERMEABILITY

Evaluation of the basin emptying times and of the positioning of the system.



APPLIED LOADS

Evaluation of the loads placed on the system for the selection of the installation stratigraphy.

EXAMPLE OF A PRELIMINARY EVALUATION

PROJECT DATA

Draining surface	5.000 m ²	Volume of rainwater to discharge	225 m ³
Outflow coefficient	1	No. DRAINPANEL	940 pcs.
Rainfalls (at least 30')	45 mm	Basin depth	2 m
Infiltration speed	10 ⁻⁴ m/s	Time of hydraulic residence (the required period of time to empty the dimensioned basin)	5.3 h

DRAINAGE

DRAINPANEL is the ideal solution for the creation of basins or draining trenches that are deeply developed. The solid and strong structure gives a high load-bearing capability to the product so that it can be placed also under heavy trafficked areas. DRAINPANEL large voids are ideal to reduce the excavation volume which is larger with the traditional gravel systems.



ACCUMULATION AND LAMINATION

DRAINPANEL should be coated with a waterproof geomembrane in order to create rainwater accumulation chambers that allow the subsequent reuse of the water. The product's conformation allows to stack the elements in many different layers, guaranteeing at the same time, a high resistance to applied loads. Moreover, thanks to DRAINPANEL high capability it is possible to store a high quantity of water in a limited place.



NEW ELEVATOR TANK

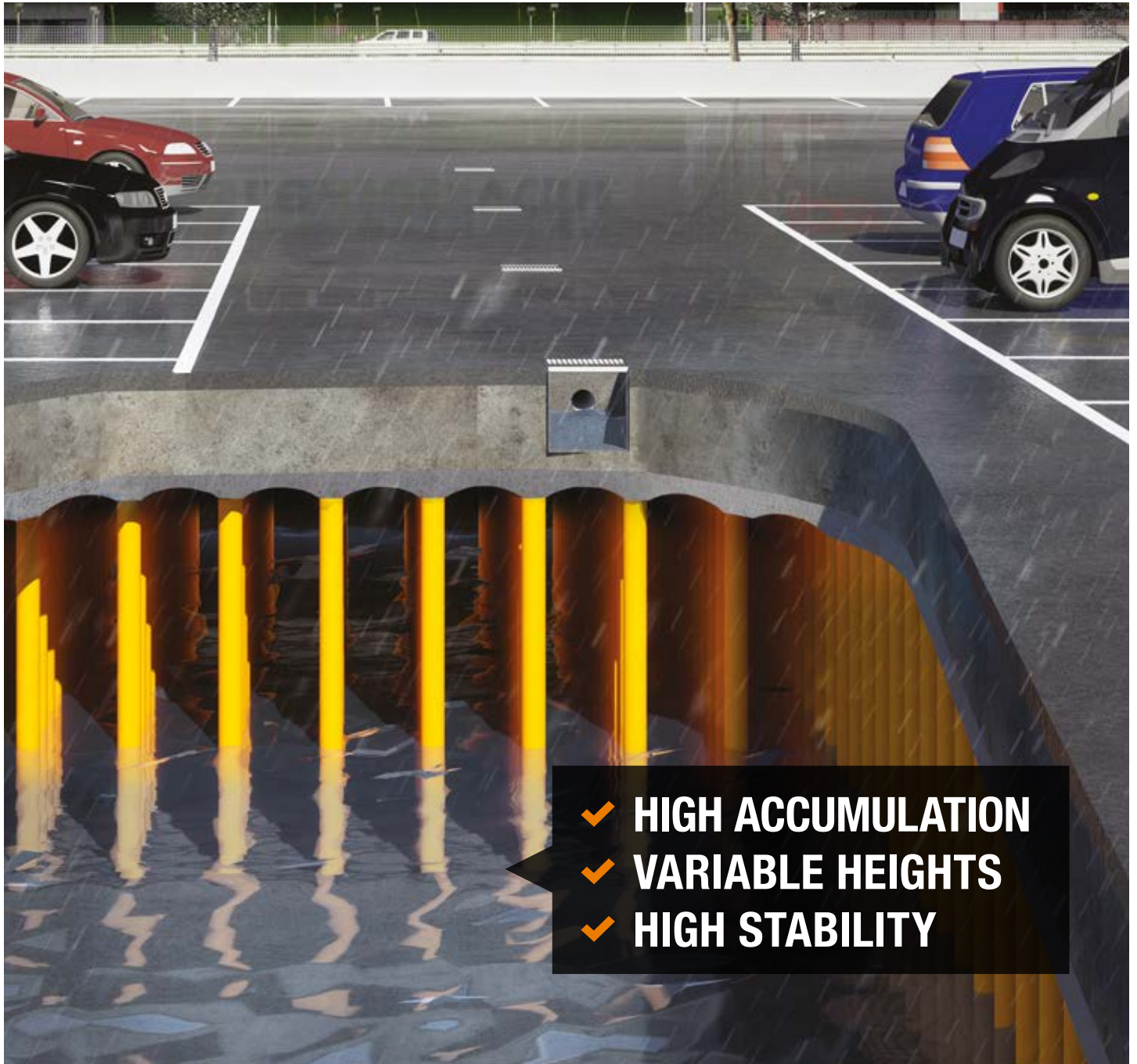

PERMANENT FORMWORK FOR IN SITU CAST CONCRETE WATER STORAGE SYSTEMS

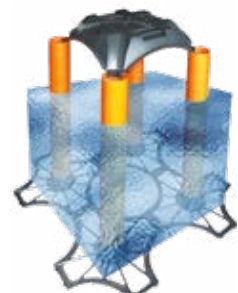

NEW ELEVATOR TANK ADVANTAGES



Permanent formwork for in situ cast concrete water storage systems.

STABLE



The base grid allows a perfect verticality of the supporting pillars, guaranteeing the load bearing capacity of the slab.

FAST



The base grid allows a faster system's installation in comparison to traditional systems. The installation surface guarantees a high worksite productivity.

INSPECTABLE



The pillars pitch permits the creation of tanks and elevations, completely inspectable through specific manholes.

RESISTANT



NEW ELEVATOR TANK structure permits the ripartition of the loads, in order to install the system also under heavy trafficked areas.

CAPACITY



NEW ELEVATOR TANK permits the creation of high capacity accumulation tanks, exploiting a small surface.

MODULAR



NEW ELEVATOR TANK is modular and can be installed easily even under curved or irregular surfaces.

NEW ELEVATOR TANK THE SOLUTION



NEW ELEVATOR TANK is a system that allows the creation of lightened and poured on-site water storage tanks, heights and size variable according to the design requirements. Not only allows NEW ELEVATOR TANK structure, a high resistance to any load and the place under heavy traffic areas, but also it guarantees a significant storage of water inside it. Moreover, the GRID, placed on the base, allows an easy and quick installation of the PVC pipes, keeping a perfect verticality during the pouring stage.

RESIDENTIAL AND COMMERCIAL BUILDINGS

FACTORIES

ROAD INFRASTRUCTURES

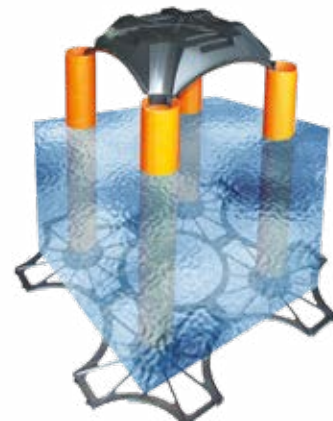

TECHNICAL DATA NEW ELEVATOR TANK

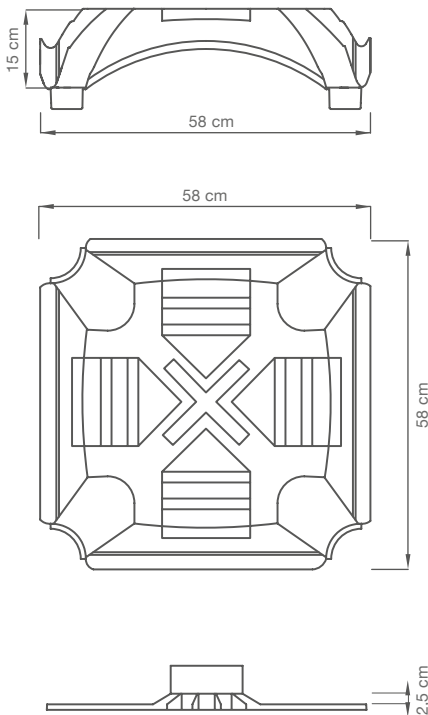

FORMWORK

GRID

Real size (cm)	58 x 58 x 15	58 x 58 x 2.5
Material	PP	PP
Weight (kg)	1,43	0,41
Packaging size (cm)	120 x 120 x 265	110 x 110 x 240
No. pcs per pallet	225	310



TUBE

LISTEL

Real size (cm)	75 > 200 x ø 12.5	8 x 10 x 100
Material	PVC	PS

LEVEL FILLING CONCRETE CONSUMPTION (m³/m²)

$$\left[0,037 \times (\text{New Elevator Tank height (m)} - 0,15) \right] + 0,030 \text{ m}^3/\text{m}^2$$

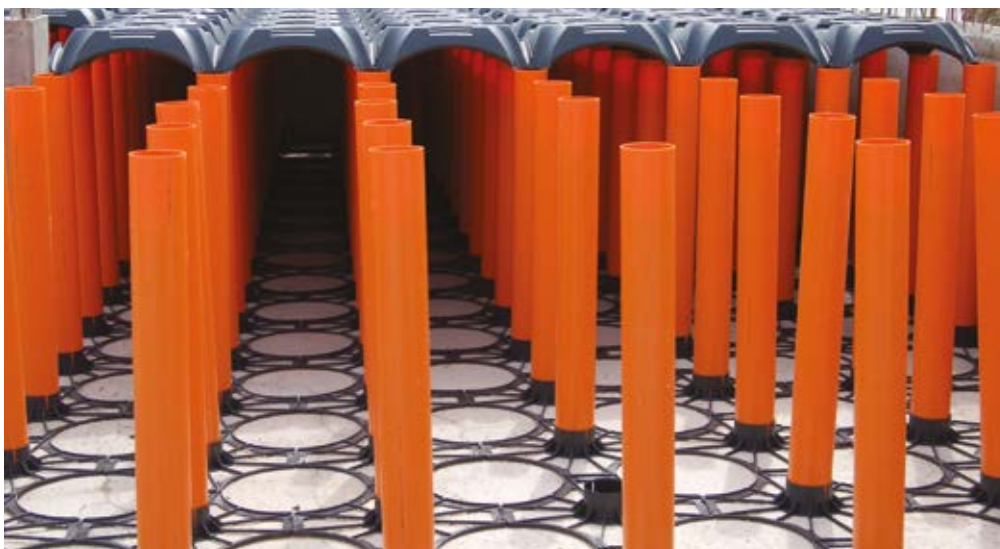

THE TUBE

The supporting pipe is the typical PVC pipe used in the worksite, the external diameter is of 125 mm and the thickness is of 1,8 mm. They are inserted in the base patented grid and once they are filled with concrete they work as structural support for the upper formwork.

NEW ELEVATOR TANK THE CONCEPT

It is ideal to create storage tanks of different heights and sizes. The product is provided with a formwork, PVC pipes and a patented grid which guarantees the system perfect verticality and a perfect load-bearing capability. The system is modular and consists in the formwork dry application in order to create a completely walkable and self-supporting foundation, ready for the pour. When the concrete solidifies, it takes the form of NEW ELEVATOR TANK creating a supporting and ventilated slab in all directions.



THE FORMWORK

It appears like a dome made of regenerated PP, plan dimensions of 58 x 58 cm and heights of 15 cm, provided with lower joints for a perfect hook with the pipes. The dome's geometry allows a uniform cargo sharing over the 4 pillars, reducing the upper slab thickness.

REINFORCEMENT OPTION

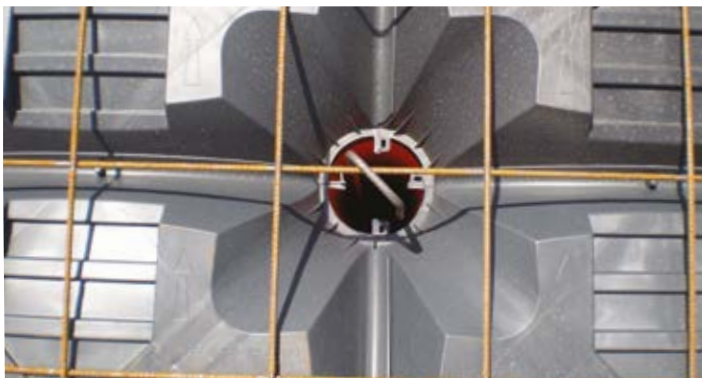

For delicate situations, where the combination between loads and pipes heights is particularly onerous, the insertion of iron elements (bars/forks made of steel) in the pipes, is recommended. This is necessary to guarantee the concrete pillars stability even under the influence of dynamic forces.

CHARACTERISTICS AND ADVANTAGES OF THE GRID

The base grid, essential for NEW ELEVATOR TANK system, is created in regenerated PP and allows the PVC pipe perfect verticality. The grids are hooked together to form a solid base grid that guarantees the structure stability and walkability.



TUBES VERTICALITY

The pillars verticality is guaranteed by the base grid, which is essential because of two aspects:

SAFETY: the perfectly aligned and vertical system guarantees safety and walkability.

BEARING CAPABILITY: it keeps the pillars perfectly vertical, so that the concrete structure will not have any distorting effect that could undermine the system stability.



Typical system without grid

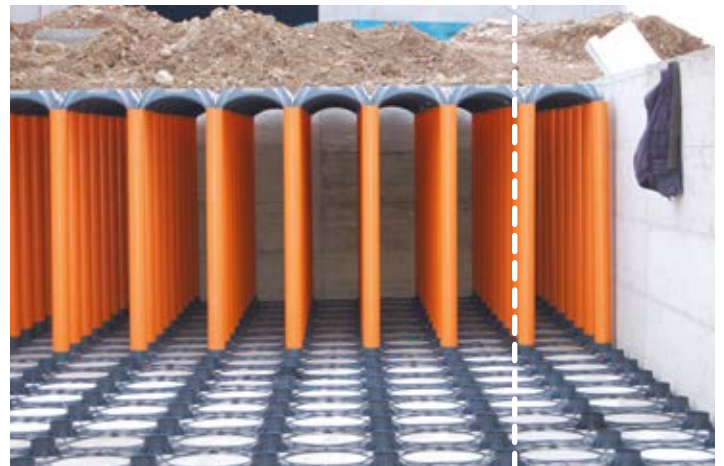

System New Elevator Tank with grid

PRECISION

The hooking between the base grids allows the vertical and horizontal alignment of the system (PVC pipes + formwork) and a high precision during the installation. The grid is very light, easy to cut and to move even in correspondence of walls.



QUICK INSTALLATION

The base grid is an essential plus for the system NEW ELEVATOR TANK. It is an extremely light and space saving element which can be quickly installed thanks to the specific male/female hooking.

NEW ELEVATOR TANK STRATIGRAPHY

- Ⓐ NEW ELEVATOR TANK GRID
- Ⓑ PVC PIPE
- Ⓒ NEW ELEVATOR TANK FORMWORK
- Ⓓ PILLAR REINFORCEMENT FORK
- Ⓔ REINFORCED SLAB
- Ⓕ GRAVEL
- Ⓖ FOUNDATION
- Ⓗ RETAINING WALLS
- Ⓘ POLYSTYRENE LISTEL
- Ⓛ SUPPORTING SHELF OF THE CUT FORMWORK
- Ⓜ STABILIZED SOIL
- Ⓝ BINDER ASPHALT
- Ⓞ WEAR LAYER

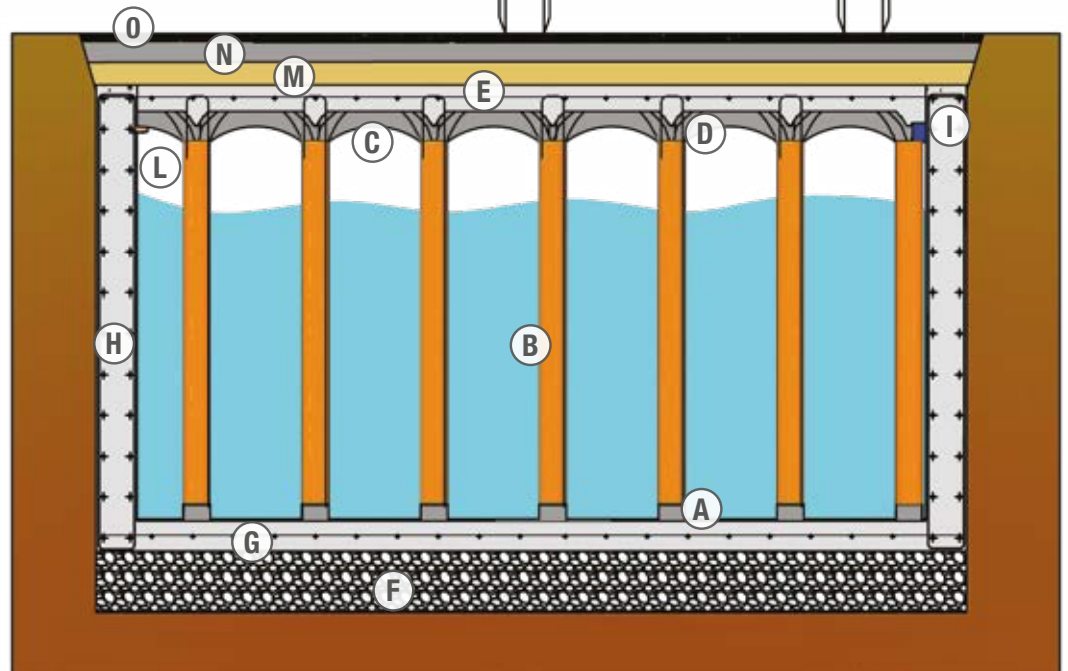

LAYING ORDER

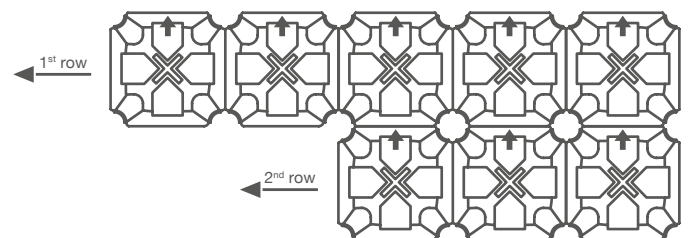
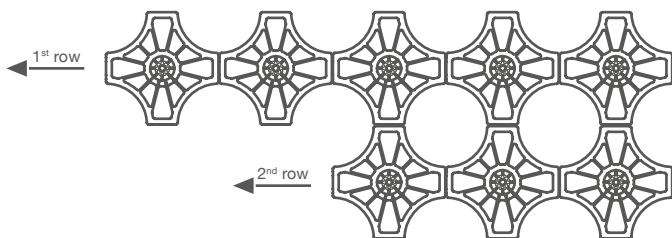

ON-SITE INSTALLATION

THE CORRECT INSTALLATION OF NEW ELEVATOR TANK



① STRUCTURE

Creation of the tank foundation and walls. Preparation of the pumping stations, the inspection pits and other hydraulic waterworks.



② GRID

Placement of the base grid, essential for the pipes verticality and for the system structural resistance.



③ TUBES

Placement of the pvc tubes, in the specific positions in the base grid.



④ FORMWORK PLACE

NEW ELEVATOR TANK, placed from right to left, is inserted into the tubes to guarantee a safe walkability.



⑤ COMPENSATION

On the starting sides, where the formwork lays against the retaining walls, the polystyrene listels avoid the concrete dispersion.



⑥ WELDED MESH

Placement of the distribution welded mesh following the design specifications



⑦ PILLARS REINFORCEMENT

Insertion of the iron rods in the PVC pipes, hooking them to the welded mesh.



⑧ THE POUR

Once the reinforcements installation is completed, you proceed with the pouring stage from a side to the other, vibrating the concrete adequately.



⑨ FINISHING

Backfill of the tank and creation of the road package.

INSTALLATION REQUIREMENTS

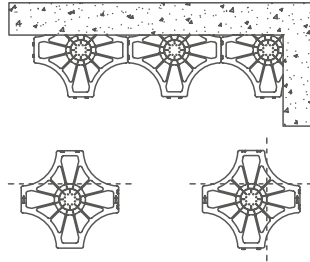

① Cut the bases as in the scheme and place the first row against the wall. Place it from right to left.

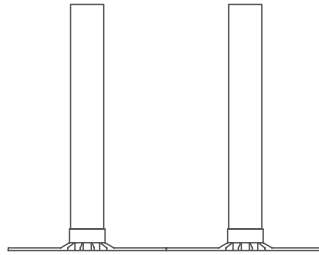

② Place the PVC pipes in the bases, exerting pressure in the upper part to obtain a correct hooking.

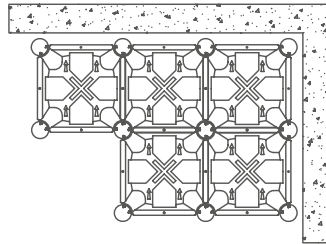

③ Install NEW ELEVATOR TANK, making sure the hooking is perfect.

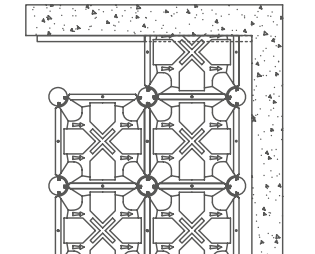
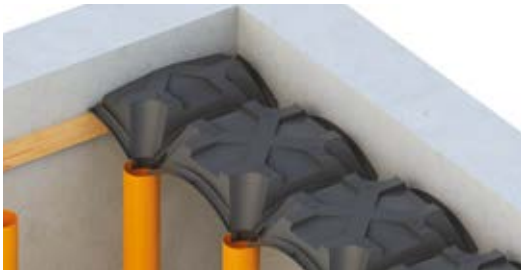

④ Place the last row of NEW ELEVATOR TANK, with the dome cut and against the kerb.

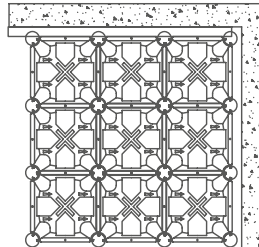

⑤ Place the stoppends against the kerb.

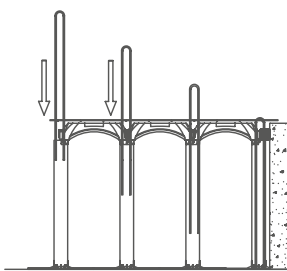

⑥ Place the welded mesh and the additional reinforcements in the pillars.

NEW ELEVATOR TANK APPLICABLE LOADS

According to the different types of applied loads, the maximal height of NEW ELEVATOR TANK changes.

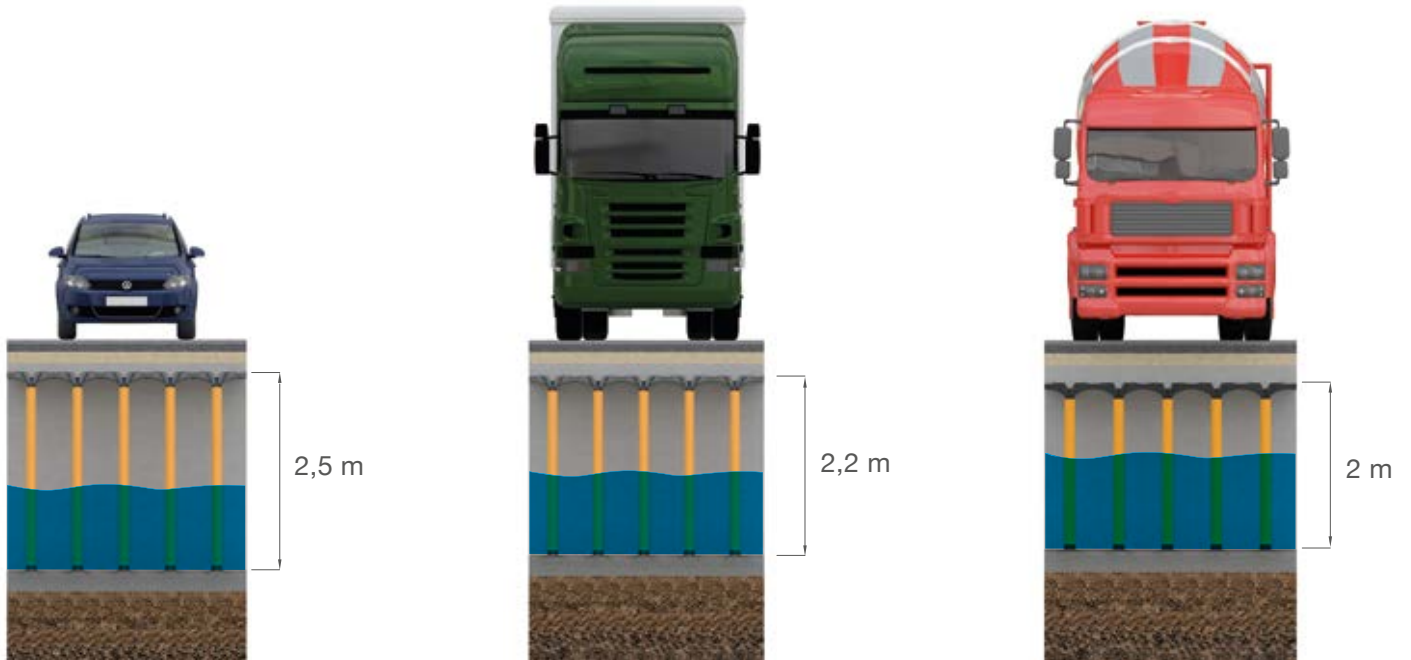

Cars

Commercial vehicles

Heavy vehicles

For a correct dimensioning of the structure contact Geoplast Spa.

DIMENSIONING PARAMETERS

REQUIRED DATA FOR THE RIGHT CALCULATION OF THE BASIN



RAINFALL

Rainfall analysis on the basis of the type of worksite.



DRAINING SURFACE

Estimation of the draining surface, applying the specific outflow coefficients.



LEGISLATION

Discharge limits, rain treatments, return times to take into consideration.



APPLIED LOADS

Evaluation of the loads, the system will bear in order to do a structural dimensioning.

CALCULATION VOLUME

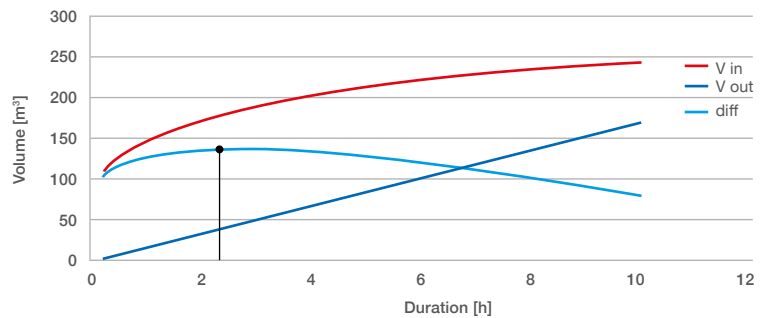

DIMENSIONING TABLES

To evaluate the tank surface you need to take into consideration reservoirs values per surface unit, as it is shown in the table below.

H	Reservoir volume		H	Reservoir volume	
cm	m³/m²	l/m²	cm	m³/m²	l/m²
80	0,626	626	170	1,493	1.493
90	0,722	722	180	1,583	1.583
100	0,819	819	190	1,686	1.686
110	0,915	915	200	1,782	1.782
120	1,011	1.011	210	1,878	1.878
130	1,108	1.108	220	1,975	1.975
140	1,204	1.204	230	2,071	2.071
150	1,300	1.300	240	2,167	2.167
160	1,397	1.397	250	2,264	2.264

The useful height of the reservoir to take into consideration, is the length of the PVC tube inserted in the base grid. The height in the table refers to the plastic system, that is the sum of the tube length and the formwork height (15 cm).

RESIDENTIAL AND COMMERCIAL BUILDINGS

NEW ELEVATOR TANK allows the creation of a lamination tank for rainwater, lightweight and poured onsite. The aim is to prevent the floodings in new urban areas and to respect the local regulations on water discharge in the sewers. The tank can alternatively be used to restore water to irrigate green areas or to create a firefighting water tank.



INDUSTRIAL BUILDINGS

NEW ELEVATOR TANK allows the creation of large size lamination tanks for rainwater, in order to prevent potential floodings or to storage high quantities of water that can be used in case of fire or as a water reserve for production purposes.



ROAD INFRASTRUCTURES

NEW ELEVETOR TANK can be used also to create storage and lamination systems for rainwater in road infrastructures. The aim is the prevention from potential viability inconveniences. The modular structure allows the quick installation of the system on irregular and curved surfaces, while the high load resistance allows its installation in heavy traffic areas. The system can be placed also under ramps or elevations thanks to the variable heights of the tubes.



ACCUMULATION TANKS FIRE PROTECTION

NEW ELEVETOR TANK permits the building of underground tanks made of concrete in order to accumulate rainwater that will be used for fire protection. The system can be customized with a chamber to place the pumps.



GEOCELL

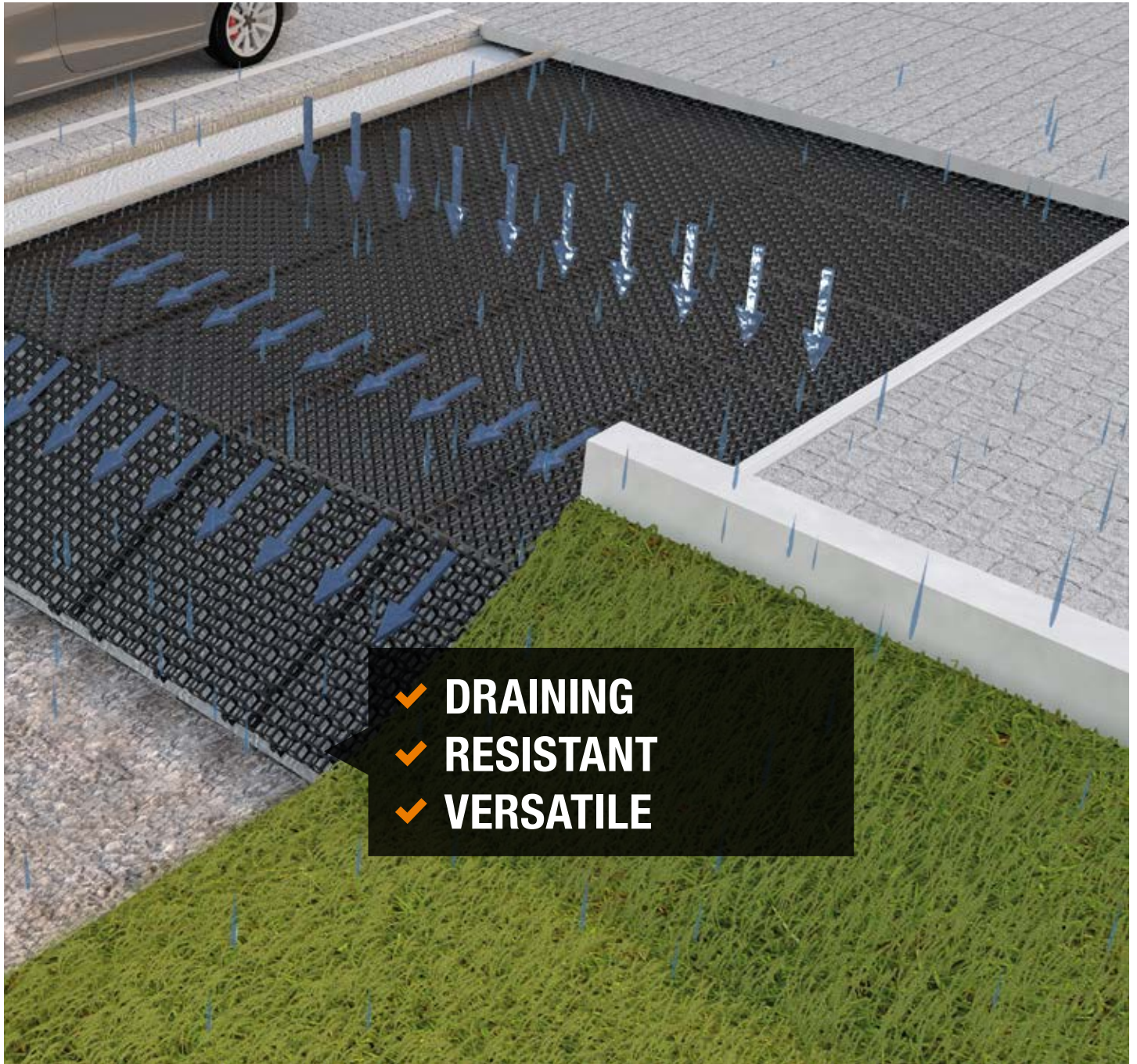

STORMWATER INSPECTABLE MODULES FOR INFILTRATION AND ATTENUATION

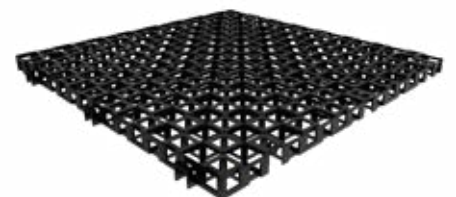

GEOCELL ADVANTAGES



High resistance grid for a widespread water drainage.

VERSATILE



GEOCELL can be used in many different contexts. In order to efficiently drain a surface or to protect underground structures.

FAST



Its light and simple installation allows a fast and safe intervention.

COUPLING



The innovative coupling system allows the rotation of the element up to 90° respect to the horizontal plane.

RESISTANT



The cells structures give GEOCELL a high resistance to flexion and compression. That's why, it can be installed under heavy trafficked areas.

CAPACITY



Thanks to its high void ratio, GEOCELL grid is able to contain up to 27 liters of water per sqm. of surface.

DRAINING



Water inside GEOCELL can flow faster than in a gravel bed, guaranteeing a more efficient water disposal.

GEOCELL THE SOLUTION

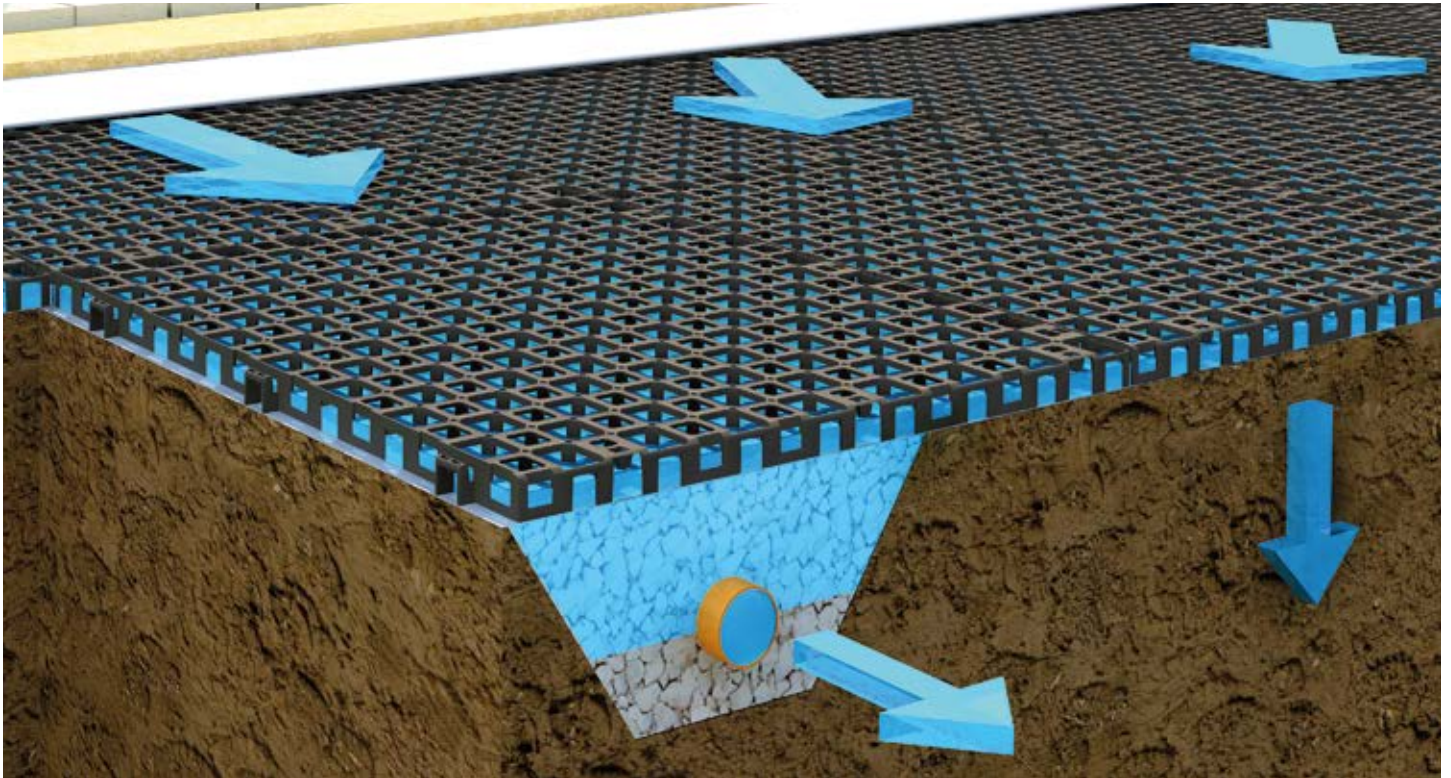

GEOCELL is a modular panel in regenerated PP designed for the creation of horizontal and vertical drainage systems for the efficient disposal of rainwater. According to the typology of installation, GEOCELL can both facilitate the disposal of water from the soil, avoiding the flooding of the surface and avoid the water stagnation protecting underground structures along with the improvement of the areas where drainage is very

difficult. It restores the natural hydrological cycle and contributes to the recharge of the aquifers. The structure of the panel combines lightness to high resistance and guarantees the transit of heavy vehicles over it. GEOCELL is the alternative solution to old-fashioned method of diffuse water drainage.

FLOORS

SPORT FACILITIES

GOLF COURSES

ROOF GARDENS

GEOTECHNICAL WORKS

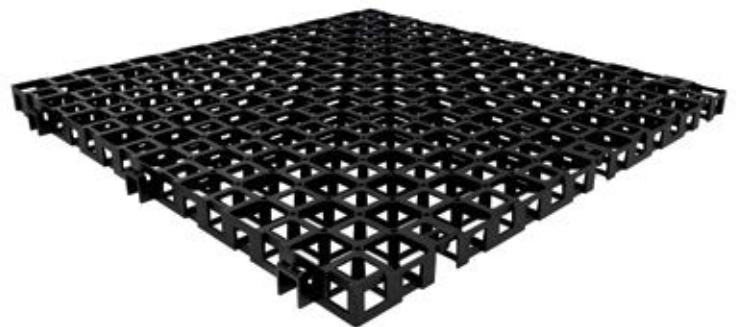

GEOCELL TECHNICAL DATA

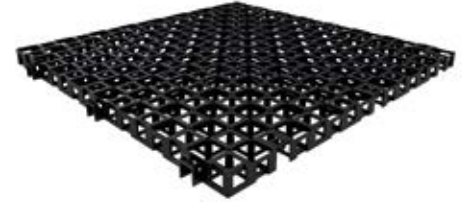
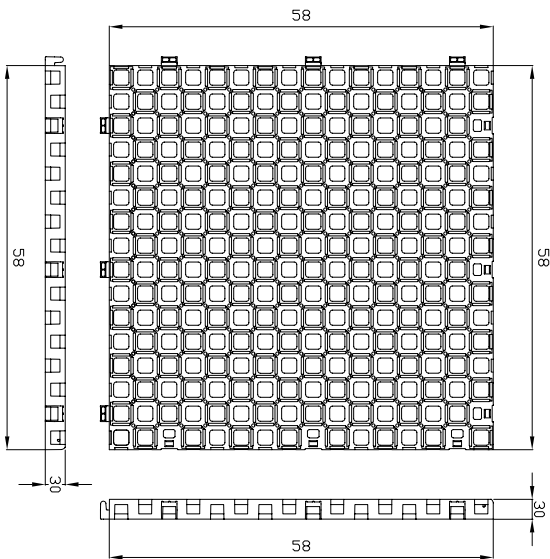

GEOCELL

Size (cm)	58 x 58 x H3
Material	PP
Void ratio (%)	91
Void percentage surf.	64
Capacity (l/m ²)	27,6
Weight per pcs. (kg)	0,97
Breaking load (t/m ²)	95*
m ² packaging	100
No. pcs. packaging	300
Packaging size (cm)	120 x 120 x H240

*It complies with requirements of DIN1072 load class SLW60

COUPLING DETAIL

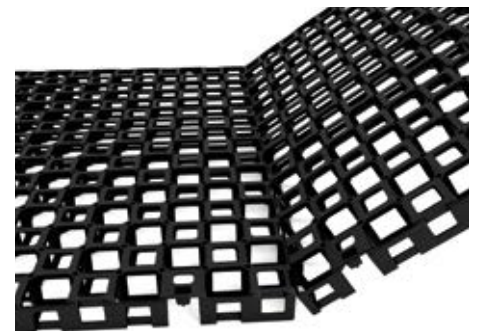
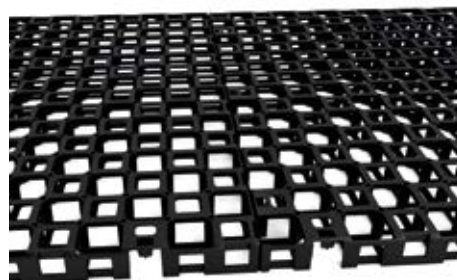

GEOCELL is made of polypropylene and it is provided with an innovative coupling that allows the mutual rotation of the panels up to a tilt of 90°. Even with the panel tilted, the coupling permits a stable connection between the elements.

Firstly, the panels need to be connected between each other through overlapping and interlocking, then it is possible to tilt one of the two elements depending on requirements.

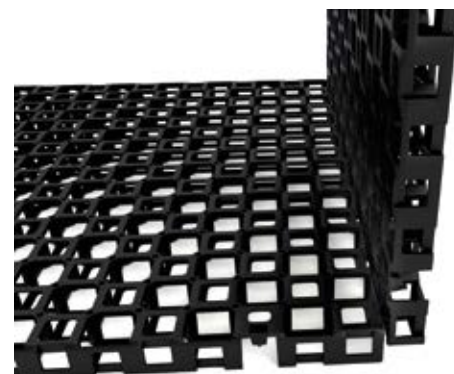

ESTIMATED INSTALLATION TIMES:

100 M²/H/WORKER

GEOCELL THE CONCEPT

In comparison to traditional systems, GEOCELL improves the drainage of the surface, guaranteeing a faster and more efficient water disposal. In this way, it is possible to avoid stagnation and water run-off problems, as well as erosions or ground elevations, when soil has a low draining capacity.

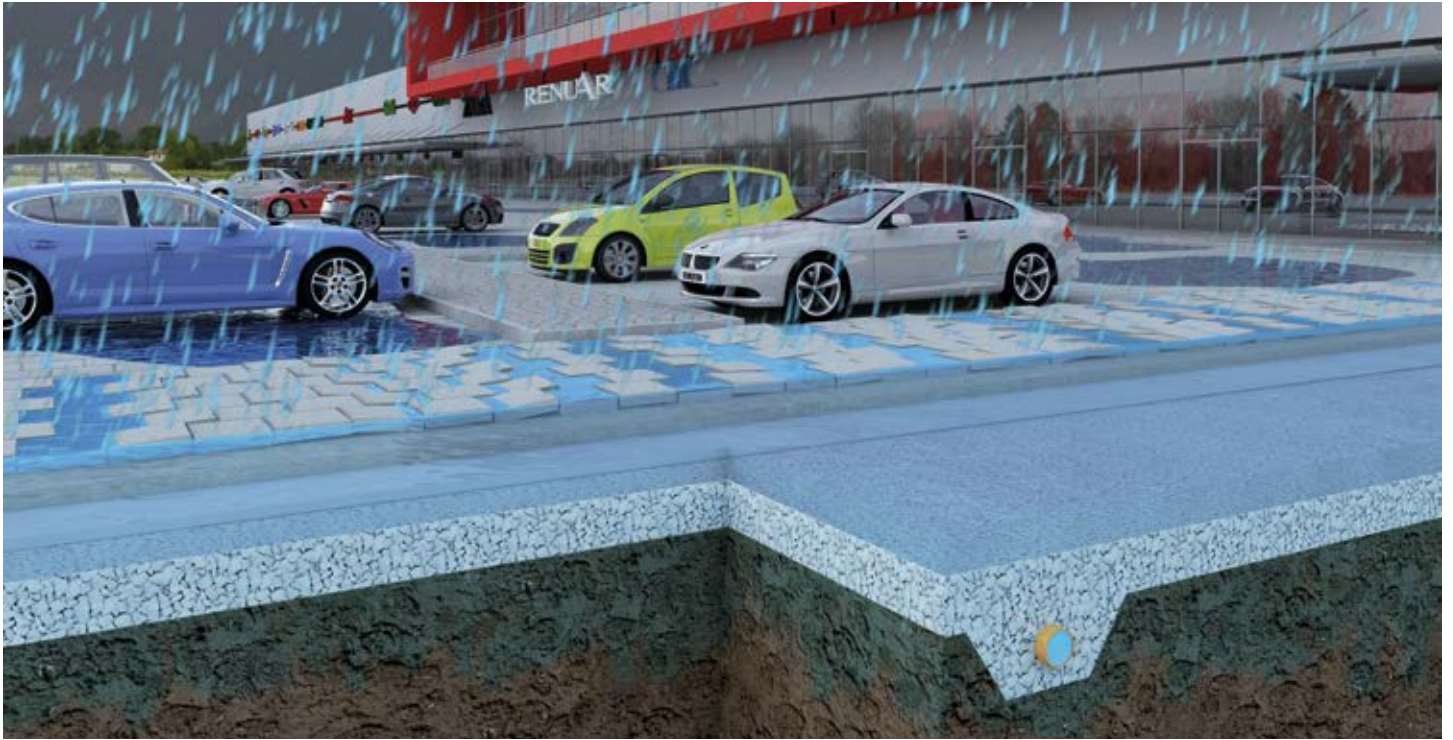

BEFORE GEOCELL



AFTER GEOCELL

COMPARISON WITH GRAVEL

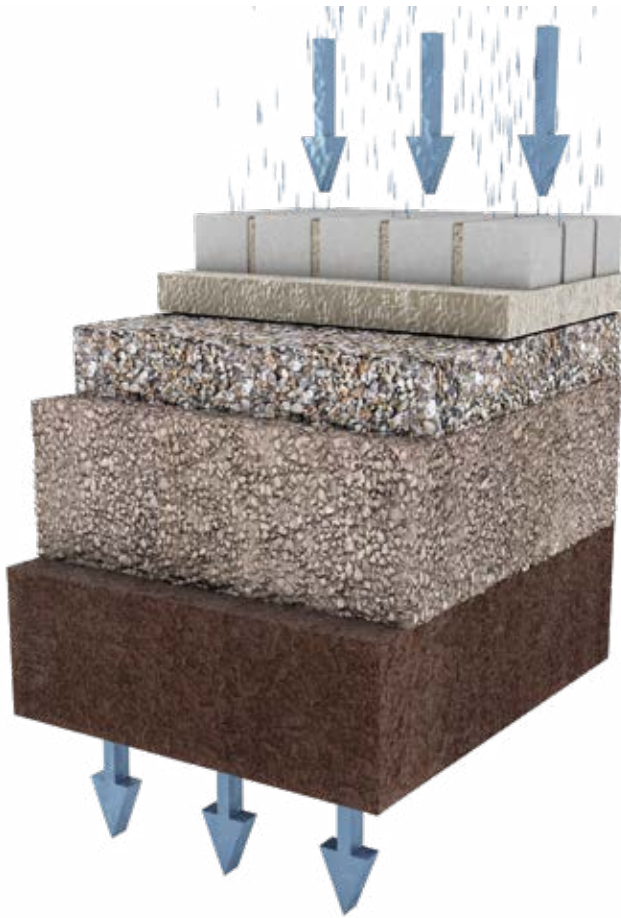

WITHOUT GEOCELL

Gravel allows a monodirectional water movement, from upward to downwards. Once the soil saturates (especially when the permeability is very low) the movement is hampered and water remains on the surface.

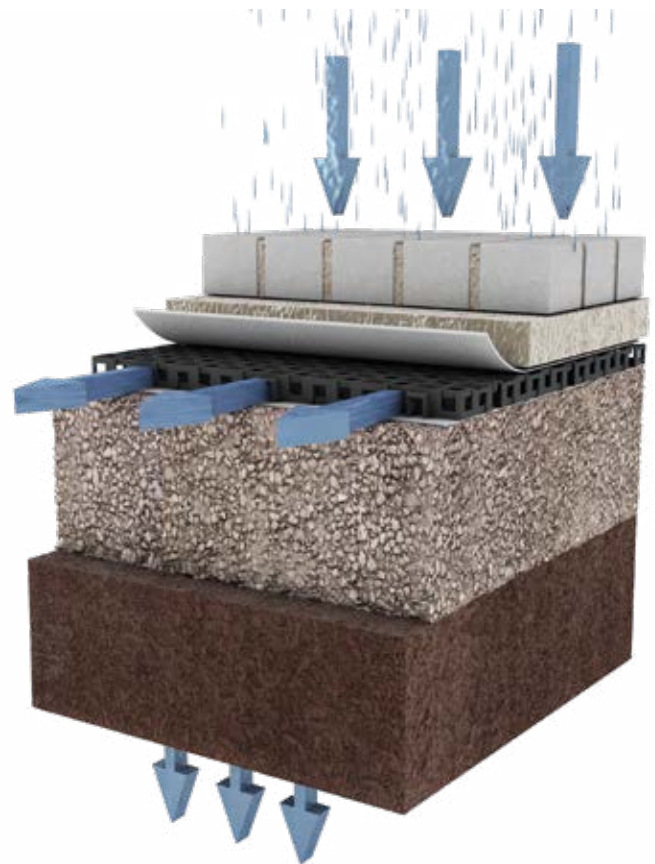

WITH GEOCELL

GEOCELL, on the contrary, allows a bi-directional water movement both along the verticality and along the floor slope, channeling water to the drainage system. In this way, water can flow horizontally avoiding the system's clogging, even in the case the underground becomes saturated and the infiltration inhibits.

VOID RATIO

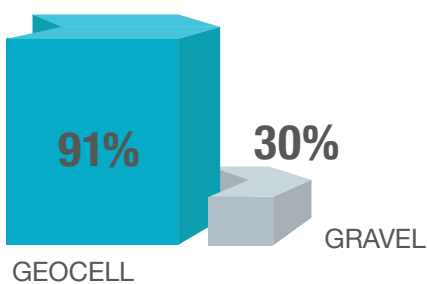

EXCAVATION DEPTH

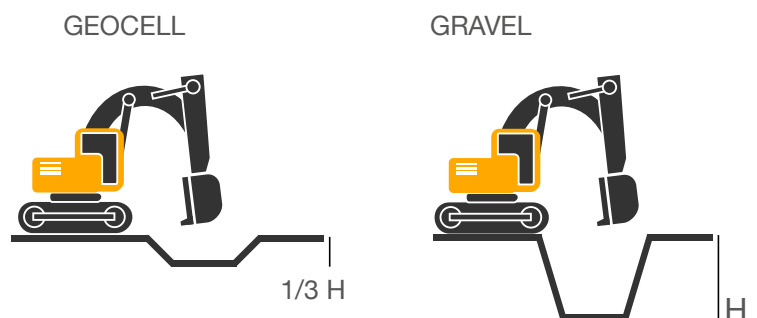

EXCAVATION DEPTH 3 TIMES LOWER

ON-SITE INSTALLATION



① PREPARATION OF THE UNDERGROUND

Laying of an underground with a well load-bearing material, well compacted and with variable thickness according to the application.



② GEO-TEXTILE INSTALLATION

Laying of a supporting geo-textile on all the surface.



③ GEOCELL INSTALLATION

Manual installation of the grid.



④ INSTALLATION OF THE PROTECTION GEO-TEXTILE

Geocell covering with a layer of geo-textile for the maintenance of a structure with a high void ratio.



⑤ COVERING

Backfilling of the system with sand or topsoil, according to the required application.



⑥ FINAL RESULT

Creation of the foreseen finishing (flooring, synthetic grass).

FLOORS

GEOCELL permits the creation of a void under permeable paved surfaces, improving their draining performance. Thanks to its vertical structure, GEOCELL guarantees a vertical drainage, favouring the rainwater infiltration in the subsoil, and an horizontal drainage, allowing a gradual water release in the network system. The high mechanical resistance, allows its usage even under heavy trafficked areas.

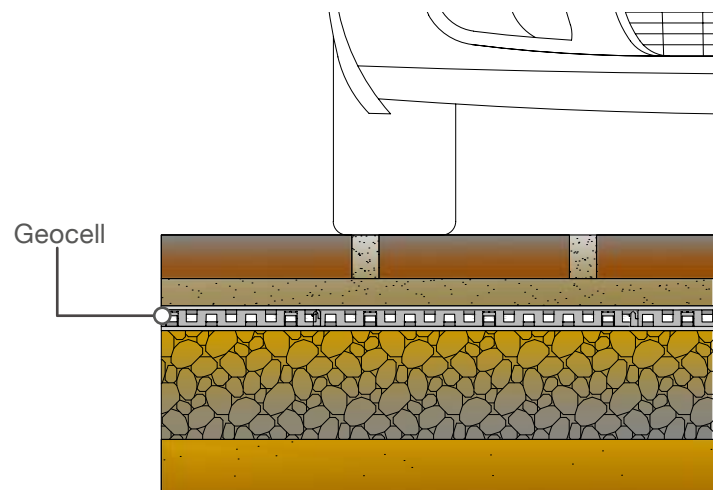

SPORT FACILITIES

GEOCELL avoids water stagnation on sport surfaces, like soccer fields in natural or synthetic grass, golf courses or tennis courts. The system creates a wide spread drainage of rainwater and guarantees the practice of sports, even with a wet weather, without affecting the sport performance. The high load bearing capacity of GEOCELL avoids also the use of high quantities of gravel for the subsoil.

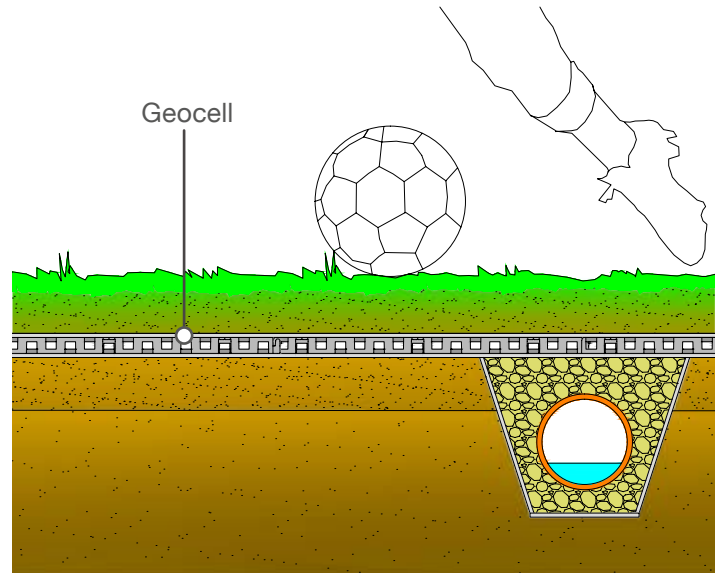

GOLF COURSES

GEOCELL allows the widespread drainage of rainwater even in golf courses, in order to avoid stagnation. Thanks to the possibility of rotating the grids, the product can be installed in areas with changing gradients, in order to follow the depressions of the ground and keep the foreseen configuration.

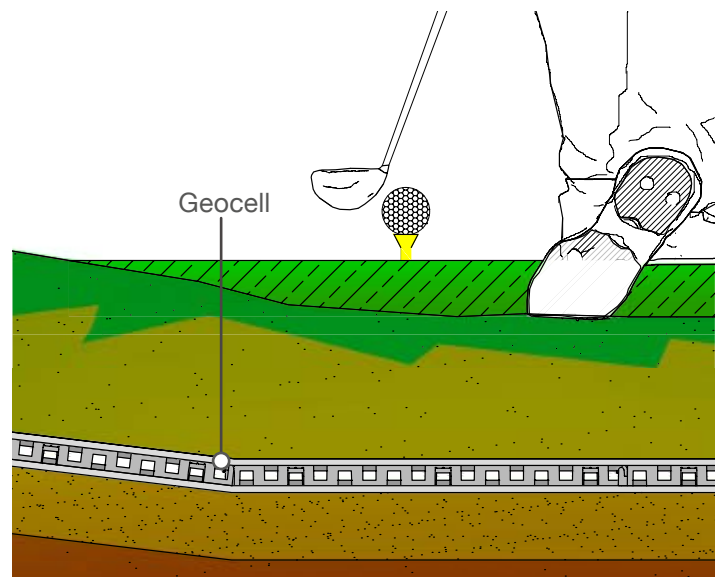
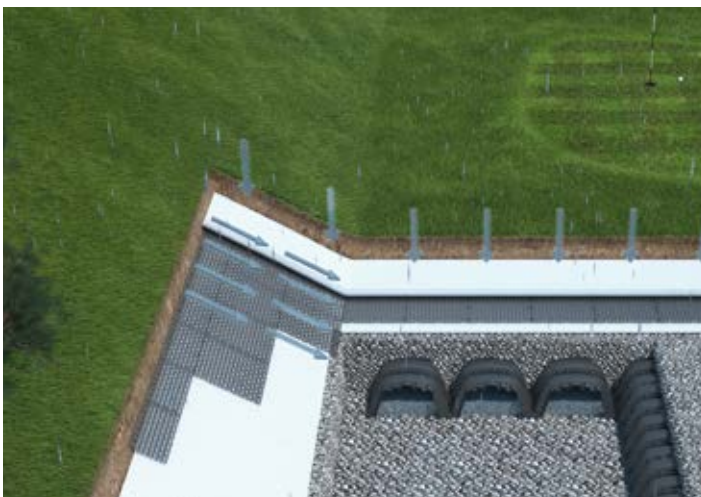

GREEN ROOF

Thanks to the high mechanical resistance and good draining capacity, GEOCELL can be used as draining sub-layer when creating roof gardens or cement flowerbeds. The panel allows a fast disposal of rainwater through the soil, guaranteeing the sheet protection and the prevention of stagnations, which damage the vegetation. Thanks to the innovative coupling that allows the panels rotation, GEOCELL can be placed also on inclined or vertical surfaces.

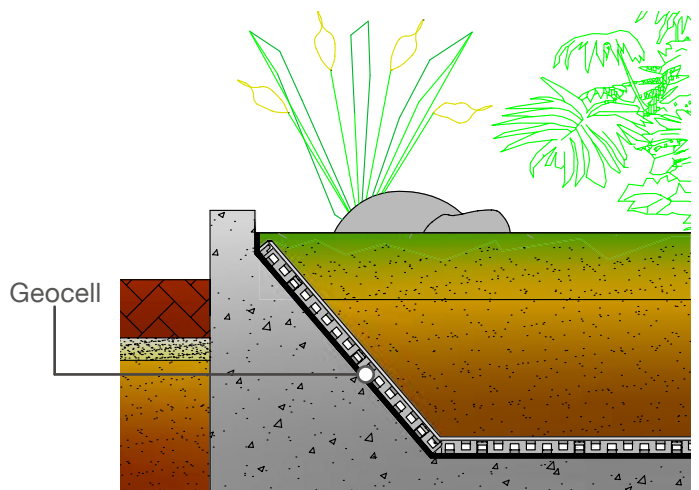

GEOTECHNICAL WORKS

GEOCELL can be used to create horizontal or vertical drainages, in order to protect foundations or retaining walls. The presence of GEOCELL reduces hydrostatic pressures and avoids the penetration of water inside the structures, protecting the waterproof membranes. The high mechanical resistance of the geo-cellular structure opposes efficiently the side thrusts of the ground, keeping the system's effectiveness intact over time.

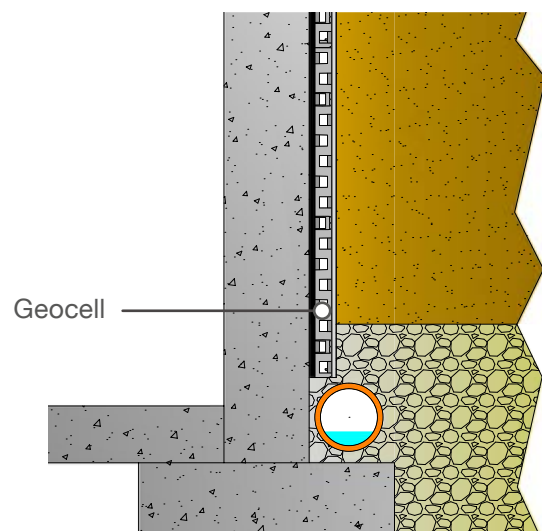



Geoplast S.p.A.

Via Martiri della Libertà, 6/8
35010 Grantorto (PD) - Italy

Tel +39 049 9490289
Fax +39 049 9494028

Geoplast@Geoplastglobal.com

GeoplastGlobal.com



ref. 08/2018

