

TECHNICAL MANUAL

NEW NAUTILUS - NEW NAUTILUS EVO

MODELING, CALCULATION, ON-SITE INSTALLATION

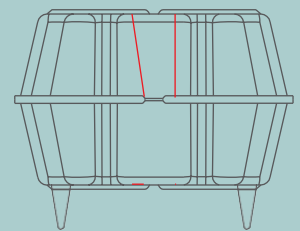
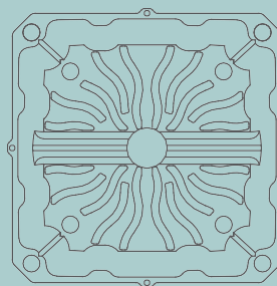
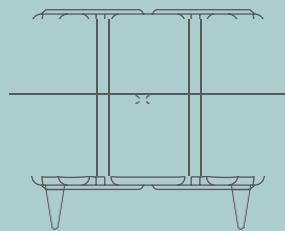
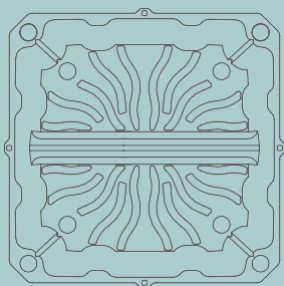

INDEX

NEW NAUTILUS EVO TECHNICAL MANUAL

1.	Introduction.....	p. 05
1.1	Slabs.....	p. 06
1.1.1	Strengths.....	p.06
1.1.2	Weaknesses.....	p.06
1.2	Lightened slabs.....	p. 07
1.2.1	Advantages.....	p. 07
1.3	Reticular slabs.....	p. 07
1.3.1	Advantages.....	p. 07
1.3.2	Weak points.....	p. 08
1.3.3	Conclusions.....	p.08
1.4	Lightened slabs with hollow articles.....	p. 09
1.4.1	Advantages.....	p.09
1.4.2	Weak points.....	p. 09
1.4.3	Conclusions.....	p. 09
1.5	Lightened slabs with hollow articles in plastic.....	p. 10
1.5.1	General characteristics.....	p. 10
2.	Technical data.....	p. 11
	Dimension tables.....	p. 12
3.	Calculation Manual.....	p. 15
3.1	Slab theory.....	p.16
3.2	Predimensioning.....	p.17
3.2.1	Determination of thickness.....	p. 17
3.2.2	Determination of the size of the minimum capital.....	p.18
3.2.3	Determination of the size of the capital so as not to have to place shear reinforcement.....	p.18
3.3	Stress calculation.....	p. 19
3.3.1	Stripe method.....	p.19
3.3.1.a	Calculation of bending moments.....	p.19
	Plate on pillars simplified calculation procedure.....	p.21
3.3.1.b	Calculation of shear stress.....	p.22
3.3.1.c	Calculation of punching.....	p.22
3.3.2	Grashof's method.....	p.22
3.3.3	F.E.M. modeling.....	p. 24
3.3.4	Practical example.....	p.27
3.4	Verification.....	p. 29
3.4.1	Calculation of flexural reinforcements.....	p.29
3.4.2	Calculation of the reinforcement stripe method.....	p. 30
3.4.2.a	Calculation of bending moments.....	p. 30
3.4.3	Calculation and verification of shear reinforcements.....	p. 33
3.4.4	Types of transverse reinforcements.....	p.34

3.4.5	Verification of the interface between concrete layers cast at different times.....	p. 34
	Regulatory requirements.....	p. 35
	Have an idea of the distance in which the shear reinforcement is inserted.....	p. 35
3.4.6	Calculation and verification to punching.....	p.35
	Calculation model - verification of the resistance on the critical perimeter.....	p.36
	Punching resistance.....	p. 37
3.4.7	Deflection control.....	p. 38
3.5.7	Construction details.....	p. 39
4.	On - site application.....	p. 41
4.1	Preparation of the formwork.....	p. 42
4.2	Laying the lower layer of the reinforcement.....	p. 43
4.3	Additional reinforcement.....	p. 43
4.4	Laying of the lightening.....	p. 44
4.5	Laying the upper layer of the reinforcement.....	p.45
4.6	Spacers.....	p.45
4.7	Shear and punching reinforcement.....	p. 46
4.8	Perimeter reinforcement.....	p. 46
4.9	Requirements for concrete casting.....	p. 46
4.10	Concrete mix design.....	p. 47
4.11	Opening of cavities before casting.....	p. 47
4.12	Opening of cavities after the construction of the slab.....	p. 48
4.13	Use of dowels and anchoring.....	p. 48
5.	Special applications.....	p. 49
5.1	Prefabrication.....	p. 50
5.2	Post-tensioning.....	p.50
5.3	Thermal activation of the masses.....	p.50
6.	Certifications.....	p. 51
6.1	Behavior during fire load and fire resistance.....	p. 52
6.1.1	500 ° C Isotherm method.....	p. 55
6.2	Acoustic behavior.....	p. 58
6.3	Thermal conductivity.....	p. 59
7.	Packaging and logistics.....	p. 61
7.1	New Nautilus Evo - standard packaging conditions for land shipment.....	p.62
8.	Appendix.....	p. 63
8.1	Kirchoff slab.....	p. 64
8.2	Stress regime.....	p. 64
8.3	Internal actions.....	p. 65
8.4	Equilibrium equations.....	p.65
8.5	Boundary conditions.....	p. 66
8.6	Internal actions on a generic section.....	p. 66



1. INTRODUCTION

1.1 Slabs

Nowadays, reinforced concrete slabs are very common structures in the construction market. Although the traditional beam slabs and hollow block slabs are still very used, other technologies have certainly gained the upper hand.

If we get a closer look at what happens around the world, beam slabs remain in use in the countries where the cost of materials are higher than labor costs.

On the other hand, the richest and the most industrialized countries, mostly use deck plate systems.

Reinforced concrete slabs:

1.1.1 STRENGTHS

The reasons are easily identifiable, as the reinforced concrete plates:

1. They are very solid thanks to the side deformation prevention, which allows them to deform less and reduce thickness:
 - a thickness reduction allows the economization of materials
 - b massing reduction, allows the maximization of the ground surface exploitation, which represents an important cost;
2. There is no need of beams:
 - a once again they allow the reduction of the volumetric footprint of the deck
 - b avoid the scaffolding of the beams
 - c facilitate the passage of the installations, significantly reducing installation times;
3. they are reinforced with meshes and straight bars:
 - a reduction of the iron reinforcements costs, since wrought iron is more expensive
 - b meshes and straight bars are easier and faster to install;
 - c it is possible to use pre-fabricated reinforced systems, in order to make the work faster (like BAMTEC layers of reinforcements)
4. they have excellent fire and acoustic behavior, thanks to their mass.

If we read the points above, it would seem that there are no reasons why we should not make our floors with slabs, however these structures also have some weak points, which in fact limit their use, in respect to other more efficient methods:

WEAK POINTS

1. They are massive structures:
 - a they consume high quantity of concrete;
 - b they are very heavy: there are large spans between the pillars, but the self-weight prevails and the result is very expensive
2. They are non-ductile structures to which the principles of the hierarchy of resistances are not applicable:
 - a cannot work on a loom;
 - b they need bracing with septa or similar;
 - c they need low structures



Figure 1 - lightened slab with New Nautilus Evo of Geoplast.

1.2 Lightened slabs

1.2.1 ADVANTAGES

To create a structure with all the characteristics and strength points of standard slabs, but without their self-weight would look like an ideal solution, but lightened slabs:

1. limit volumes
2. eliminate beams/straight soffit;
3. concrete is less expensive;
4. allow larger spans;
5. allow optimization of vertical structures;
6. reduce foundation load
7. reduce excavation load

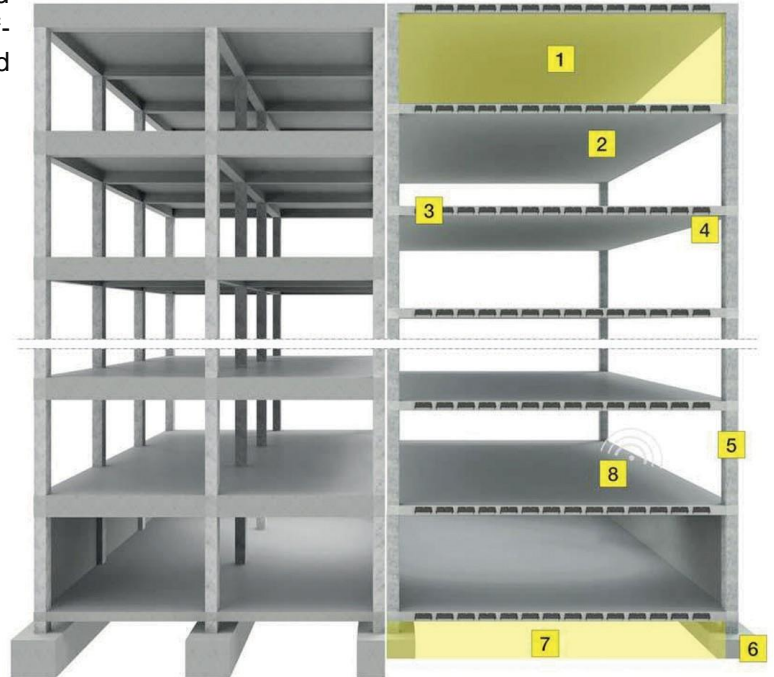

1.3 RETICULAR SLABS

The slabs maintain their bidirectional structure and create an orthogonal grid through the installation of

disposable blocks (in concrete or terracotta) or reusable (in plastic or fiberglass). Leaving massive capitals in the pillars for the punching.

1.3.1 ADVANTAGES

The advantages offered by this type of solution, are multiple:

1. these are slabs without beams;
2. the quantity of concrete needed is reduced;
3. they are very light;
4. less steel is used;
5. the blocks to make the grids are very cheap.

1.3.2 WEAK POINTS

These structures also have some disadvantages:

1. they lose a lot of inertia compared to the massive slabs of equal thickness, so they must compensate for the greater deformability with higher thicknesses;
2. if they do not comply with certain geometric parameters, they do not have sufficient torsional stiffness to get a SLAB, therefore they have lower performance than the equivalent FULL slab;
3. they must be reinforced grid by grid similar to the beams, with consequent slowing of the laying process;
4. they do not have good acoustic behavior;
5. they have a mediocre fire behavior (no more than REI 90");

6. due to the considerable deformability they have a limited range of use of lights and loads;
7. in the case of recoverable blocks, except for some particular applications, they need a false ceiling.

1.3.3 CONCLUSIONS

This type of solution is ideal alternative to the slab and maintains its characteristics and advantages but in a well-defined field of application, apart from these applications they become less competitive.



Figure 2 - example of reticular slab

1.4 LIGHTENED SLABS WITH HOLLOW ARTICLES

Hollow articles are embedded in the pour, they are usually made of cubic shaped low-density polystyrene or plastic. Blocks remain embedded in the pour and create a grid of ribbings, which are enclosed between two massive

upper and lower slabs.

1.4.1 ADVANTAGES

This solution is more efficient than most reticular slabs:

1. presence of the lower slab makes it perfect for all the purposes;
2. the same thickness or even lower thickness of a full slab can be maintained;
3. lightness and concrete savings are guaranteed;
4. they can be reinforced in the same way as massive slabs
5. quantity of steel is reduced
6. they have good acoustic behavior;
7. great fire behavior (up to REI 240')
8. there is no need of a false ceiling.

1.4.2 WEAK POINTS

These structures also have some disadvantages:

1. in comparison to reticular slabs they consume more concrete and weight more;
2. they consume more steel with the same concrete consumption and inertia compared to the reticular slabs, due to the lower lever.

1.4.3 CONCLUSIONS

This type of solution is ideal for narrow spans and reduced loads can be economically less interesting than the reticular slab, despite having clearly superior performances.

On the contrary, it is absolutely competitive if compared to the full slab solution, especially in the range of thicknesses from 28 to 60 cm, and spans between 8 and 14 m.

1.5 LIGHTENED SLABS WITH HOLLOW ARTICLES IN PLASTIC

1.5.1 GENERAL CHARACTERISTICS

In the last 10-15 years ago, lightened slabs were created through the use of cubic blocks in low density polystyrene.

This construction technology had some disadvantages:

1. blocks were fragile and suffer from weathering (water imbibition)
2. blocks were occupying a lot of space and did not facilitate worksite logistics
3. It was difficult to block them and keep them lifted by inferior reinforcements.
This made it necessary to cast the lower slab, lay and block the lightened slabs, complete the installation of the reinforcements and complete the casting. This practice made work time-consuming;
4. in case of fire it has been shown that the polystyrene sublimates creating overpressure inside the hollow that can cause explosions of the slabs, furthermore these gases are toxic.

During recent years a new technical method has arrived in the market. This solution finally allows the

overrun of these limitations. Those are recycled polypropylene formworks, 52 x 52 cm with variable height.

They can be "single", or "double", by putting together two "single".



Figure 3 – layout of lightening New Nautilus Evo double



Figure 4 – Plastic lightening "single" type.



Figure 5 – Plastic lightening "double" type.



2. TECHNICAL DATA

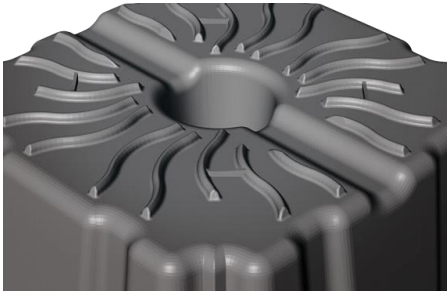

THE UPPER SPACER



In the upper section of the formwork there are uniformly distributed spacers 8 mm thick.

These elements allow the upper reinforcement to be placed directly over the formwork in order to guarantee a suitable concrete covering.

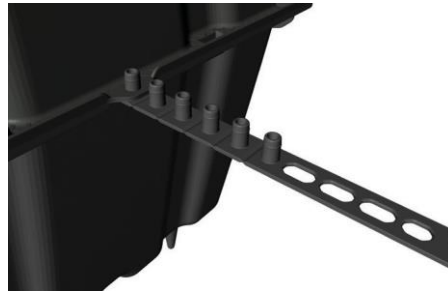

THE SIDE TAB



Every formwork is provided with side spacers that allow the correct installation of the elements according to the width of the beams, which is to be calculated during the design stage. The elements are marked from 100 to 200 mm and can be hooked to the side loops.

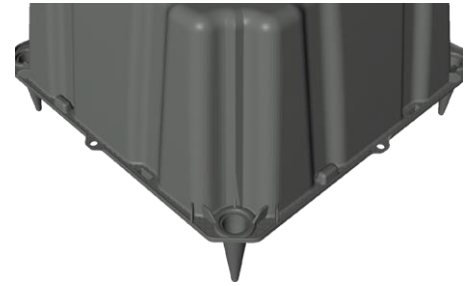

THE LOWER FOOT



The lower spacer feet are integral elements of the formwork: they are molded with the rest of the formwork and allow the creation of the lower slab with a thickness evaluated during the design stage. The feet have a variable height from 50 to 100 mm.

DIMENSIONAL TABLES

NEW NAUTILUS EVO SINGLE

NEW NAUTILUS EVO DOUBLE

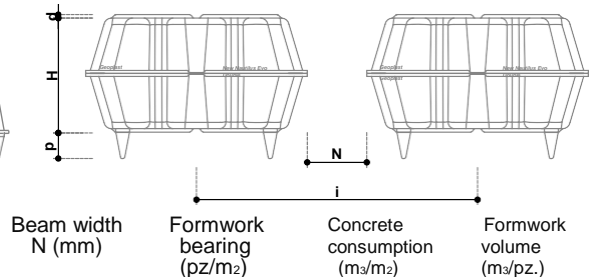
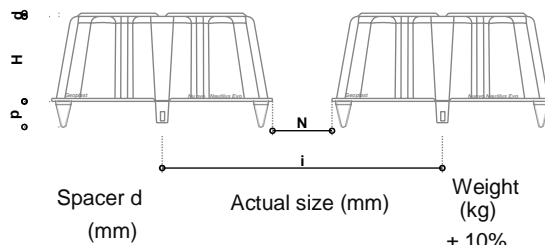
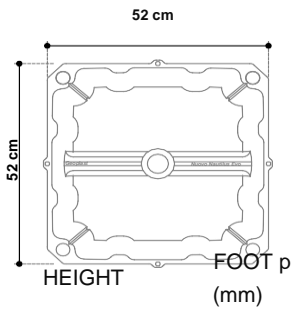

		Spacer d (mm)	Actual size (mm)	Weight (kg) ± 10%	Beam width N (mm)	Formwork bearing (pz/m ²)	Concrete consumption (m ³ /m ²)	Formwork volume (m ³ /pz.)
H10 SINGLE	0-50-60-70-80-90-100	8	520 x 520 x H100	1.12	100	2.60	0,038	0,024
					120	2.44	0,041	
					140	2.30	0,045	
					160	2.16	0,048	
					180	2.04	0,051	
					200	1.93	0,054	
H13 SINGLE	0-50-60-70-80-90-100	8	520 x 520 x H130	1.18	100	2.60	0,057	0,028
					120	2.44	0,062	
					140	2.30	0,066	
					160	2.16	0,069	
					180	2.04	0,073	
					200	1.93	0,076	
H16 SINGLE	0-50-60-70-80-90-100	8	520 x 520 x H160	1.25	100	2.60	0,077	0,032
					120	2.44	0,082	
					140	2.30	0,087	
					160	2.16	0,091	
					180	2.04	0,095	
					200	1.93	0,098	
H20 SINGLE	0-50-60-70-80-90-100	8	520 x 520 x H200	1.35	100	2.60	0,099	0,039
					120	2.44	0,105	
					140	2.30	0,110	
					160	2.16	0,116	
					180	2.04	0,120	
					200	1.93	0,125	
H24 SINGLE	0-50-60-70-80-90-100	8	520 x 520 x H240	1.45	100	2.60	0,120	0,046
					120	2.44	0,128	
					140	2.30	0,134	
					160	2.16	0,141	
					180	2.04	0,146	
					200	1.93	0,151	
H28 SINGLE	0-50-60-70-80-90-100	8	520 x 520 x H280	1.55	100	2.60	0,142	0,053
					120	2.44	0,151	
					140	2.30	0,158	
					160	2.16	0,165	
					180	2.04	0,172	
					200	1.93	0,178	

HEIGHT	FOOT p (mm)	Spacer d (mm)	Actual size (mm)	Weight (kg) ± 10%	Beam width N (mm)	Formwork bearing (pz/m ²)	Concrete consumption (m ³ /m ²)	Formwork volume (m ³ /pz.)
H20 DOUBLE	0-50-60-70- 80-90-100	8	520 x 520 x H100 + H100	2.24	100	2.60	0,099	0,048
					120	2.44	0,105	
					140	2.30	0,110	
					160	2.16	0,116	
					180	2.04	0,120	
200	1.93	0,125						
H23 DOUBLE	0-50-60-70- 80-90-100	8	520 x 520 x H100 + H130	2.30	100	2.60	0,095	0,052
					120	2.44	0,103	
					140	2.30	0,111	
					160	2.16	0,118	
					180	2.04	0,124	
200	1.93	0,130						
H26 DOUBLE	0-50-60-70- 80-90-100	8	520 x 520 x H130 + H130	2.36	100	2.60	0,114	0,056
					120	2.44	0,123	
					140	2.30	0,131	
					160	2.16	0,139	
					180	2.04	0,146	
200	1.93	0,152						
H29 DOUBLE	0-50-60-70- 80-90-100	8	520 x 520 x H130 + H160	2.43	100	2.60	0,134	0,060
					120	2.44	0,144	
					140	2.30	0,152	
					160	2.16	0,160	
					180	2.04	0,168	
200	1.93	0,174						
H30 DOUBLE	0-50-60-70- 80-90-100	8	520 x 520 x H100 + H200	2.47	100	2.60	0,136	0,063
					120	2.44	0,146	
					140	2.30	0,155	
					160	2.16	0,164	
					180	2.04	0,171	
200	1.93	0,178						
H32 DOUBLE	0-50-60-70- 80-90-100	8	520 x 520 x H160 + H160	2.50	100	2.60	0,154	0,064
					120	2.44	0,164	
					140	2.30	0,173	
					160	2.16	0,182	
					180	2.04	0,189	
200	1.93	0,197						
H33 DOUBLE	0-50-60-70- 80-90-100	8	520 x 520 x H130 + H200	2.53	100	2.60	0,156	0,067
					120	2.44	0,166	
					140	2.30	0,176	
					160	2.16	0,185	
					180	2.04	0,193	
200	1.93	0,201						
H34 DOUBLE	0-50-60-70- 80-90-100	8	520 x 520 x H100 + H240	2.57	100	2.60	0,158	0,070
					120	2.44	0,169	
					140	2.30	0,179	
					160	2.16	0,189	
					180	2.04	0,197	
200	1.93	0,205						
H36 DOUBLE	0-50-60-70- 80-90-100	8	520 x 520 x H160 + H200	2.60	100	2.60	0,175	0,071
					120	2.44	0,187	
					140	2.30	0,197	
					160	2.16	0,206	
					180	2.04	0,215	
200	1.93	0,223						
H37 DOUBLE	0-50-60-70- 80-90-100	8	520 x 520 x H130 + H240	2.63	100	2.60	0,177	0,074
					120	2.44	0,189	
					140	2.30	0,200	
					160	2.16	0,210	
					180	2.04	0,219	
200	1.93	0,227						
H38 DOUBLE	0-50-60-70- 80-90-100	8	520 x 520 x H100 + H280	2.67	100	2.60	0,180	0,077
					120	2.44	0,192	
					140	2.30	0,203	
					160	2.16	0,213	
					180	2.04	0,223	
200	1.93	0,231						
H40 DOUBLE	0-50-60-70- 80-90-100	8	520 x 520 x H200 + H200	2.70	100	2.60	0,197	0,078
					120	2.44	0,210	
					140	2.30	0,221	
					160	2.16	0,231	
					180	2.04	0,241	
200	1.93	0,250						
H41 DOUBLE	0-50-60-70- 80-90-100	8	520 x 520 x H130 + H280	2.73	100	2.60	0,199	0,081
					120	2.44	0,212	
					140	2.30	0,224	
					160	2.16	0,235	
					180	2.04	0,245	
200	1.93	0,254						
H44 DOUBLE	0-50-60-70- 80-90-100	8	520 x 520 x H200 + H240	2.80	100	2.60	0,219	0,085
					120	2.44	0,232	
					140	2.30	0,245	
					160	2.16	0,256	
					180	2.04	0,267	
200	1.93	0,276						
H48 DOUBLE	0-50-60-70- 80-90-100	8	520 x 520 x H240 + H240	2.90	100	2.60	0,241	0,092
					120	2.44	0,255	
					140	2.30	0,269	
					160	2.16	0,281	
					180	2.04	0,292	
200	1.93	0,303						
H52 DOUBLE	0-50-60-70- 80-90-100	8	520 x 520 x H240 + H280	3.00	100	2.60	0,262	0,099
					120	2.44	0,276	
					140	2.30	0,293	
					160	2.16	0,306	
					180	2.04	0,318	
200	1.93	0,329						
H56 DOUBLE	0-50-60-70- 80-90-100	8	520 x 520 x H280 + H280	3.10	100	2.60	0,284	0,106
					120	2.44	0,301	
					140	2.30	0,317	
					160	2.16	0,331	
					180	2.04	0,344	
200	1.93	0,356						



3. CALCULATION MANUAL

3.1 SLAB THEORY

The slabs are a type of two-dimensional structural elements which, preserving their thicknesses, combine excellent structural performance, fast installation as well as economic and functional advantages.

The structural behavior of the slab elements is characterized by the prevailing flexural behavior (flexion, shear, torsion), which ensures a transfer of loads along orthogonal paths according to a single preferential direction or two or more preferential directions, therefore dividing into "mono-directional slabs", in the first case, or, "bidirectional slabs" in the second case.

The loads that weigh on the slab can be transmitted in various ways, both point-wise and continuously, therefore the following categories of slabs can be identified:

- slab with constant thickness on columns with or without capital (flat slab);
- slab with variable thickness, with local thickening in correspondence of the columns (mushroom slab);
- slabs on edge beams, placed on two or four sides;
- slabs on load-bearing walls.

As far as the calculation phase is concerned, the codes are generally related to the elastic analysis, therefore in the absence of cracking, and ignoring the reinforcement, acceptable hypotheses in the verification phase at the operating limit states.

On the contrary, when the ultimate limit states are taken into consideration, the behavioral non-linearity, due to the concrete cracking and the plasticizing of the steel, is necessarily taken into consideration.

Certainly, the key to understanding the many aspects of the mechanical behavior of the slab is still provided by the theory of elasticity, in the hypothesis of small displacements. The elastic model, based on the hypothesis of displacement continuity, tensions and deformations, makes it possible to preserve the concept of internal action as the local resultant force of the tensions that are having effect on a unitary section, whatever the nature of the stress.

A reference to the elastic method is obliged.

As for the lightened slabs, the shape of the box configures the slab as a series of crossed ribs closed above and below by two slabs of variable thickness by choice.

Experimental results found in the appendix certify that this structure maintains the same nature and behavior as an orthotropic slab according to EC2.

According to Eurocode 2, in fact, in the structural analysis may not be necessary to decompose the ribbed or lightened slabs into discrete elements, as long as the wing or the upper structural part and the transverse ribs have adequate torsional stiffness.

This assumption is valid if:

- the pitch of the ribs does not exceed 1500 mm;
- the height of the rib, below the wing, is not more than 4 times its width;
- the thickness of the wing has equal or greater value than the highest value between 1/10 of the net span between the ribs and 50 mm;
- there are transverse ribs distant from each other no more than 10 times the total thickness of the slab.

A different pitch of the ribs leads to a different bending-resistant mechanism; in fact, in a mono-directional slab, the zones of slab that are more distant from the rib itself do not appear to be fully collaborating.

Following the same logic, the distribution of the normal stresses in slab and counter-slab that are created due to the flexing of the deck are concentrated near the ribs and are decreasing while moving further from them (a phenomenon called shear moment).

This kind of behavior is less important for the structures in question, since the ribs on two sides prevent the behavior from being purely one-way.

3.2 Predimensioning

3.2.1 Determination of thickness

The constructive configuration in which the technology New Nautilus EVO expresses its potential to the maximum, that of a bidirectional plate, in the situation such as to have a relation between the spans in the two orthogonal directions expressed as:

$$\frac{L_x}{L_y} \in \left\{ 1 < \frac{L_x}{L_y} < 1.7 \right\}$$

Outside this range the behavior becomes purely mono-directional.

A first way to obtain an indicative size of the slab thickness is with simple proportions, based on structural types in use and spans to be covered:

- full plate on pillars $d = \frac{L}{25}$
- lightened plate on pillars $d = \frac{L}{28}$
- full plate on beams $d = \frac{L}{30}$
- lightened plate on beams $d = \frac{L}{32}$

The minimum size of the upper and lower slabs is constrained by minimum covering requirements to be secured to the bars. Inside the slab the minimum reinforcement covering required by the regulations must be ensured for the category of exposure relating to the calculation hypotheses made, plus the two diameters of the basic reinforcement in the two directions.

The thickness of the slab is considerably reduced, compared to a basic reinforcement composed of elements with electro-welded meshes, if a loose bar solution are used.

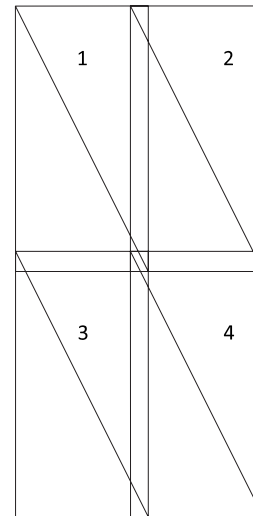

Figure 6 - arrangement of electro-welded meshes.

As you can see from the drawing, the position of armatures containing electro-welded meshes gives the necessary overlapping, at least partial, in the border areas between two adjacent meshes. In the small section belonging to all four of the designed meshes it will be necessary to have the space to place eight bars in the slab, plus the space for necessary distances between the lower bar and the upper side of the slab, and between the upper bar and the formwork, in a way that allows a correct flow of the concrete pour.

To these geometric estimations we must add fire safety considerations; in fact, greater thicknesses fit with better fire load resistance.

The size of the ribs is also related to the type of additional reinforcements required; in fact, if it is required and it is decided to reinforce the ribs, it must be done in a way that the bars inside them can be placed, ensuring at the same time a correct distance from the formworks, as well as reinforcement gap.

The minimum spacing must be such that:

$$C_{barre} > \max \left\{ \varphi_x^{max}; \varphi_y^{max}; 20 \text{ mm} \right\}$$

Furthermore, more massive ribs, as it will be shown later, correspond to greater shear resistance, therefore a larger size may be required to handle high stresses.

3.2.2 Determination of the size of the minimum capital

It is advisable to leave, in the vicinity of the support areas of the slab (columns, load-bearing walls), areas without lightened slabs, in order to allow the transmission of shearing actions by having the resistance of the full zone.

The extension of the capitals over the pillars can be calculated in the first instance by taking as the minimum extension the one that contains the punching perimeter able to resist without reinforcement, and in any case the one not inferior than 2.75 from the edge of the pillar, where d is the useful height of the section.

The critical perimeter, u_{out} has the following expression, as defined in Eurocode 2 at point 6.4.5 (4), as it was also shown previously:

$$u_{out} = \frac{\beta \cdot V_{Ed}}{v_{Rd,c} \cdot d}$$

Therefore, when the dimension of the circumference is obtained, it is easy to go back to the radius, and therefore to the minimum size of the capital:

$$R_{cap} = \frac{u_{out}}{2\pi}$$

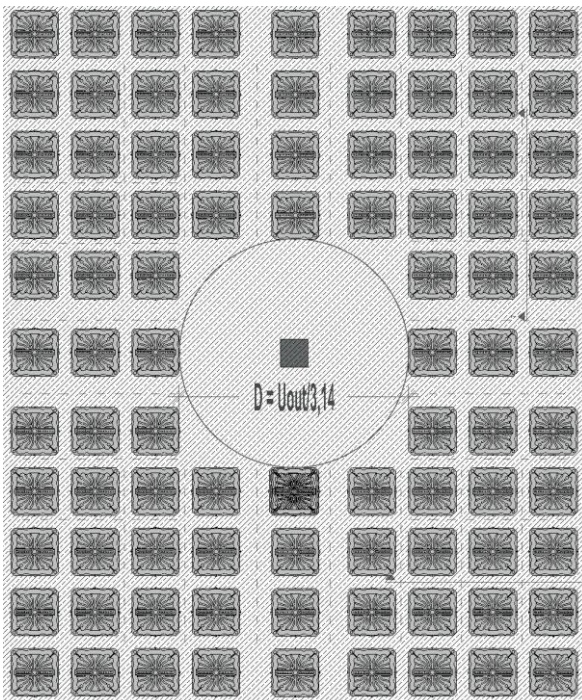

Figure 7 - non-lightened concrete area dimensions - capital

3.2.3 Determination of the size of the capital so as not to have to place shear reinforcement

If you do not want to implement a shear verification, and reinforce the slab ribs, you can enlarge the full slab area, so that the stress in the lightened area is always inferior or equal to the resistant shear of the sole concrete.

An idea of what the size of the capital should be in order to achieve this result can be obtained as follows:

Let's consider a slab consisting of an infinite series of fields, with spans going in the two directions, L_x and L_y let's analyze this pillar; this pillar will have a capital with the following dimensions, $C_x \cdot C_y$ subject to a load; we exclude the contribution of the load on the capitals, which, strongly reinforced for negative bending and punching, can be here considered as rigid constraints.

The vertical action directed to the remaining portion of the deck is:

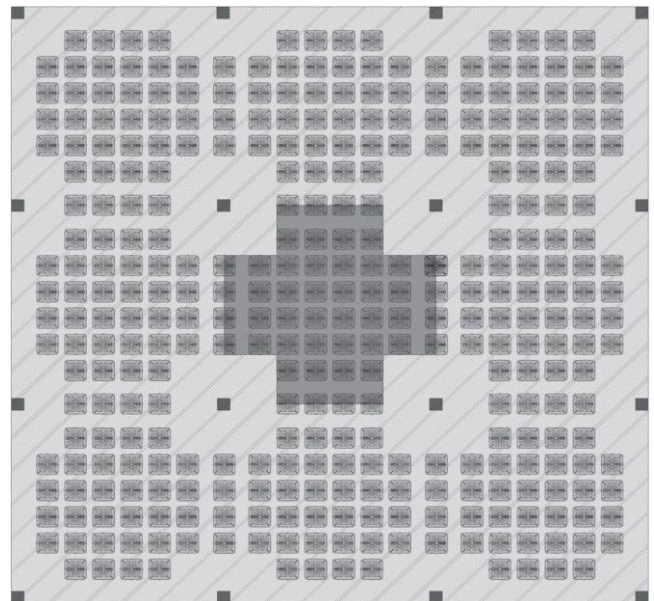

Figure 8 - area subject to a considered shearing action

$$V_{Ed} = p \cdot \left(L_x \cdot L_y - 4 \cdot \frac{C_x}{2} \cdot \frac{C_y}{2} \right)$$

This action is counterbalanced by the resistant shear of the ribs at the interface between the capitals and the remaining portion of the slab, which can be expressed as:

$$V_{Rd} = n \cdot V_{Rd,C} = \frac{4 \cdot \left(\frac{C_x}{2} + \frac{C_y}{2} \right)}{i} \cdot V_{Rd,C}$$

Where $V_{Rd,C}$ is resistant cut of the sole concrete of the rib, is the number of ribs that contribute, that can be calculated as the perimeter of the capitals in the considered field, divided by i interaxial spacing between the ribs.

Therefore, the total resistant action is the sum of the resistant actions of the ribs.

By equating stress and resistance, I can look for the size of the capital C_x, C_y , which satisfies the relation; in case you want to provide square capitals, the equation is simplified to:

$$p \cdot (L_x \cdot L_y - c^2) = \frac{4 \cdot c \cdot V_{Rd,C}}{i}$$

This is a second-degree equation solvable in: c

$$c^2 \cdot [p] + c \cdot \left[\frac{4 \cdot V_{Rd,C}}{i} \right] - p \cdot L_x \cdot L_y = 0$$

Alternatively, it is possible to look for the capital dimensions, keeping the dimensions distinct C_x and C_y , but a further equation should be inserted to make the system resolvable; for example it can be set that the relation between C_x and C_y , is the same as that between L_x and L_y .

3.3 Stress calculation

3.3.1 Strip method

3.3.1.a Calculation of bending moments

Within the Static Method, the ultimate limit state of a plate is characterized by the achievement of the limiting moment in one or more sections.

Therefore, the range of moments must obey the equation of the flexural equilibrium of the plate:

$$\frac{\partial^2 M_x}{\partial x^2} + 2 \cdot \frac{\partial^2 M_{xy}}{\partial x \cdot \partial y} + \frac{\partial^2 M_y}{\partial y^2} = -p(x, y)$$

There are a priori infinite moment fields able to satisfy this equation, but there is only one exact solution, corresponding to the formation of the kinematics.

With the exception of a limited number of simple cases, it is practically impossible to determine the exact solution

without the use of automatic calculation. However, it is possible to obtain satisfactory solutions, even if approximate, regardless of the formation of a mechanism, as proposed for example by Hillerborg, whose Strip Method is easy to use.

This method disregards the torsion, so the equation of equilibrium becomes:

$$\frac{\partial^2 M_x}{\partial x^2} + \frac{\partial^2 M_y}{\partial y^2} = -p(x, y)$$

In the slotted plate there are at least three torsion-resistant mechanisms, and therefore, in principle, the torsion cannot be ignored. However, when the reinforcement is being sized (objective of the Hillerborg method), it is cautious not to take into account the torsion as the three mechanisms mentioned above (torsion in the compressed zone, aggregate mashing in the slotted plates and wedge action of the reinforcements) too often depend on factors that are not part of the designer's control, such as the extension of the compressed zone, the opening of the slots and the local flexural stiffness of the reinforcement.

This hypothesis of neglected torsion corresponds to a hypothesis of a mechanical model including the plate made of a set of strips arranged in the x and y directions, each subject to bending and shearing.

Therefore, the strips arranged along the line x absorb a part of the load, $\alpha \cdot p$ and the strips in the y direction the remaining part $(1 - \alpha) \cdot p$

this can be translated with the equations:

$$\frac{\partial^2 M_x}{\partial x^2} = -\alpha \cdot p_u$$

$$\frac{\partial^2 M_y}{\partial y^2} = -(1 - \alpha) \cdot p_u$$

For practical reasons, variable values cannot be assigned to the coefficient with continuity, but constant values in zones.

The plate must therefore be divided into zones, each with its own value α . The choice of this value must be made on the basis of the most effective flexion in the transmission of the boundary load, according to the following criteria:

Since two bent strips intersect in each dx dy areola of the plate, one parallel to the x axis and the other parallel to the y axis, the load acting on that areola is transmitted to the boundary mainly by the strip that is more rigid during flexion (with less span, and/or with more rigid end constraints and/or connecting the areola with the nearest constraint); therefore, in the transmission of the load to the boundary, prevails the direction $x (\alpha \rightarrow 1)$ or direction $y (\alpha \rightarrow 0)$ depending on whether the strip aligned with x or the strip aligned with y is locally more rigid.

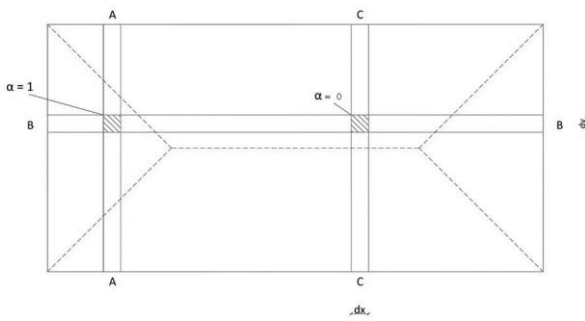

Figure 9 - representation of the strip method according to Hillerborg.

In details:

plate uniformly constrained to the boundary: to the areas closest to the sides aligned with the y axis higher values of α must be assigned (between 0.5 and 1), while to the areas closest to the sides aligned with the x, small values of α must be assigned (between 0 and 0.5) figure A.

For zones that are have the same average distance between two equally bound sides, it is also reasonable to set $\alpha = 0.5$ and to adopt a distribution as in figure B.

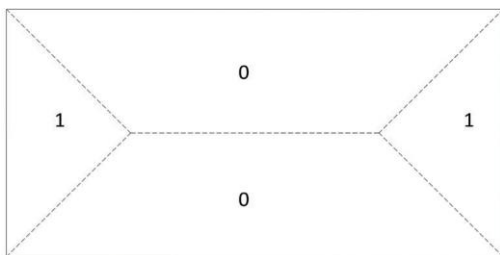

Figure 10 - possible distribution (A) in a rectangular plate leaning on the boundary.

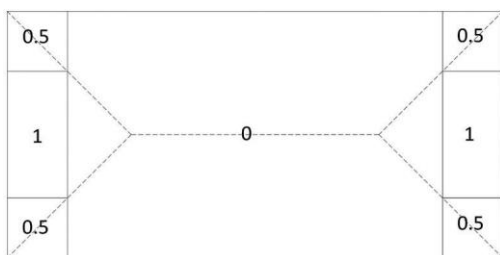

Figure 11 - possible distribution (B) in a rectangular plate leaning on the boundary.

Plate with constraints to mixed boundaries: the proximity to a joint aligned with y results in larger values of α , while the proximity to a free edge aligned with y results in a null value of α , since it is not possible (due to lack of constraint and structural continuity) any load transmission in the x direction (orthogonal to the edge itself).

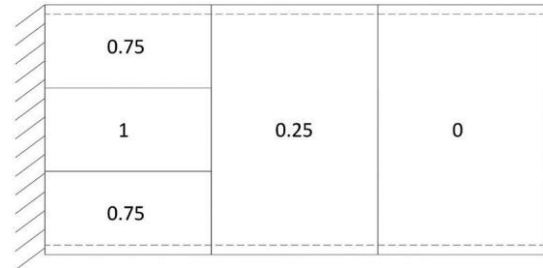

Figure 12 - possible redistribution in a rectangular plate with constraints to mixed boundaries.

The strip method also gives reason for the so-called "handles", which are boundary areas for the slots, and act as real support beams for the strips that are orthogonal to them and that are interrupted by the presence of the slot.

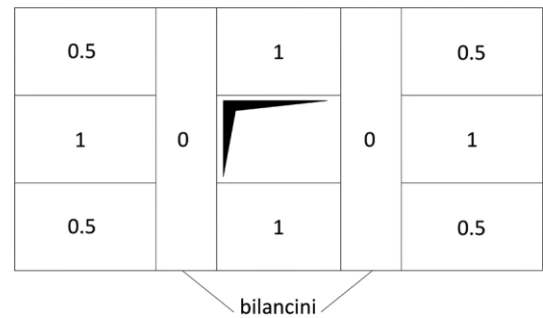

Figure 13 - example of plate with slot and handles (assigned geometric dimensions).

In each strip the reinforcement must be sized on the basis of the maximum moment (the sizing is conservative):

$$m_{xu} = m_{xu}(\alpha, p_u, P_u)$$

or

$$m_{yu} = m_{yu}(1 - \alpha, p_u, P_u)$$

It should be noted that we have always talked about reinforcement sizing, although in reality the strip method makes it possible to evaluate the resistant moments of the requested reinforcement.

$$m_{xu} = A_x \cdot f_{yd} \cdot z; m_{yu} = A_y \cdot f_{yd} \cdot z$$

In these formulas the thickness of the plate appears through the internal lever arm $z=0.8 \cdot t$, therefore if, as is usual, the thickness of the plate t is assigned, the reinforcements are dimensioned; but if the reinforcement is assigned the thickness is dimensioned.

Plate on pillars simplified calculation procedure

The design of a plate field on pillars under the action of a vertical load w can be simplified as follows. For obvious balance reasons, the sum of the resultant moments M^+ e M^- and, along the sections at the pillars and in the span, in the x direction, must be equal to the total moment caused by load, $w \cdot l_x \cdot l_y^2 / 8$; an analogous diagram can be taken into account for the moments in the y direction.

Taking into consideration the dimensions of the sections of the pillars, follows a reduction of the maximum moment caused by loads compared to the case of a point support; it is possible to consider a value of span reduced by half the size of the pillar at each end. Considering, for example, the y direction, with span l_y and pillar of size, b_y , it is possible to derive a total bending value in the direction equal to:

$$M_T = M^+ + M^- = \left(1 - \frac{b_y}{l_y}\right)^2 \cdot w \cdot \frac{l_x \cdot l_y^2}{8} < w \cdot \frac{l_x \cdot l_y^2}{8}$$

The sizing of the reinforcement is carried out by dividing this total moment into a positive moment in the span, and a negative one at the support section, identified by the line connecting two pillars. The percentage of M_T carried by each section is determined by referring to the distribution of the bending moments of the elastic solution. According to the assumption of Parker and Gamble it is possible to divide the total moment in the two directions:

$$M_T = \left(1 - b_y / l_y\right)^2 \cdot w \cdot l_x \cdot l_y^2 / 8$$

or

$$\left(1 - b_x / l_x\right)^2 \cdot w \cdot l_y \cdot l_x^2 / 8$$

attributing 65% to the negative moments in the support, and the remaining 35% to positive moments in the span. From this observation a design process was born which divides the plate into two strips, a lateral one, which connects the pillars, and a central one, each of which carries part of the total moment; the basis of this method is therefore the use for the design of the average values of bending moments. The percentages of the total moment that are carried by each strip are always chosen with reference to the elastic solution: 70% of the negative moment M^- is assigned to the lateral strip at the columns, and 30% to the central strip.

On the other hand, the positive moment is divided equally, 50% to the lateral strips, 50% to the central ones. The lateral strip can be represented as divided into two parts of which each one occupies 20% of the width of the field (in total they occupy 40% of the width, the central one 60%).

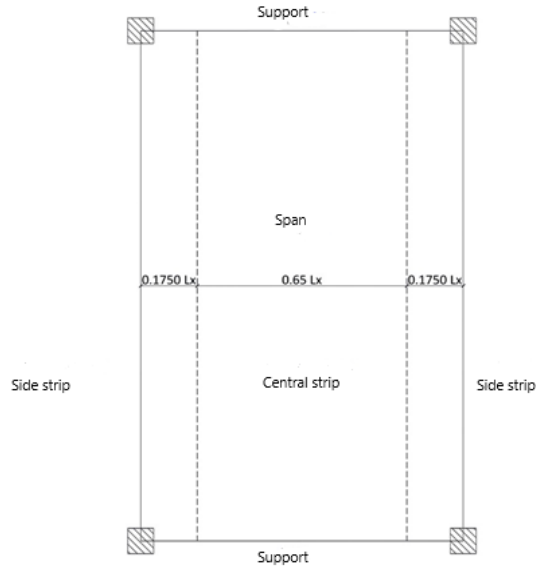

Figure 14 - diagram for the calculation of design moments in the y direction - width of the central and lateral strips.

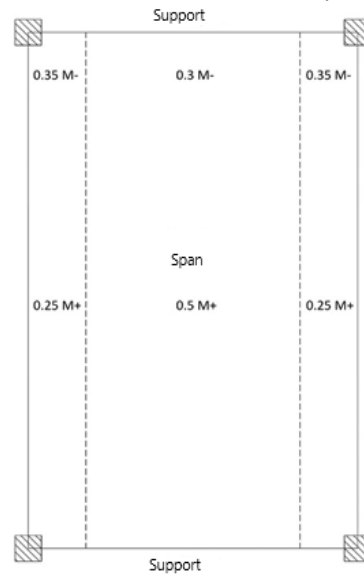

Figure 15 - diagram for the calculation of the design moments - moments of competence of each strip.

Since the previous divisions are made starting from the elastic solution, it is advisable to proceed without redistributing the moments between the values in the supports and those in the span, in order to have a good behavior of the structure, with cracking and limited deflections. Another reason for avoiding redistributions is the danger of plates punching in correspondence with the support on the pillars, which can be facilitated by the cracking due to the flexion and yielding of the reinforcements in these areas.

3.3.1.a Calculation of shear stress

Let's consider a slab consisting of an infinite series of fields, with spans in the two directions L_x and L_y , and capital with dimensions C_x , C_y , subject to a load p :

assuming that the shear resulting from the reaction of the pillars is absorbed by the capitals (verification to punching of the pillar), the lightened plate must be able to withstand the shear force resulting from the vertical load and acting on the portion of the slab shown on the following figure:

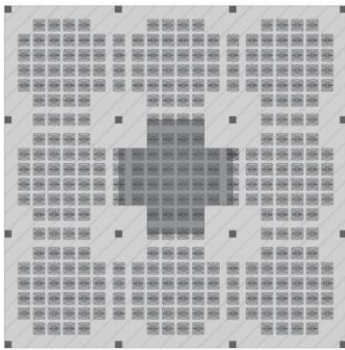

Figure 16 - area subject to a considered shearing action

$$V_{Ed} = p \cdot \left(L_x \cdot L_y - 4 \cdot \frac{c_x \cdot c_y}{4} \right)$$

This action must be absorbed by the ribs at the interface between the capitals and the remaining portion of the slab.

The shear force for each of the ribs will therefore be:

$$V_{Ed} = n^{\circ} \cdot v_{Ed} = \text{int} \left\{ \frac{4 \cdot \left(\frac{c_x}{2} + \frac{c_y}{2} \right)}{i} \right\} \cdot v_{Ed,C}$$

$$v_{Ed,C} = \frac{V_{Ed} \cdot i}{4 \cdot \left(\frac{c_x}{2} + \frac{c_y}{2} \right)}$$

Calculation of punching

If p is the last load acting on the plate, the capitals must be able to withstand the reaction of the pillar equal to:

$$P_{Ed} = p \cdot L_x \cdot L_y$$

3.3.2 Grashof's method

An alternative simplified method is based on an analysis that compares the plate behavior to a fictitious beam. This analysis is based on the deformation of the plate fields due to evenly distributed loads. It is imagined a division of the slab field into many strips, at the infinitesimal limit, a and b , that are orthogonal to each other. The distributed load will be carried by the strip of the full slab according to a bidirectional behavior; the two strips in which the generic plate field has broken down will carry a load rate based on the stiffness of the strips, these rates will be found through the application of the following approximate formula (Grashof):

$$q_a = q \cdot \frac{b^4}{K \cdot a^4 + b^4}; \quad q_b = q_{TOT} - q_a$$

Once the competent load has been determined for strips a and b , the simplification of a continuous beam model can be applied.

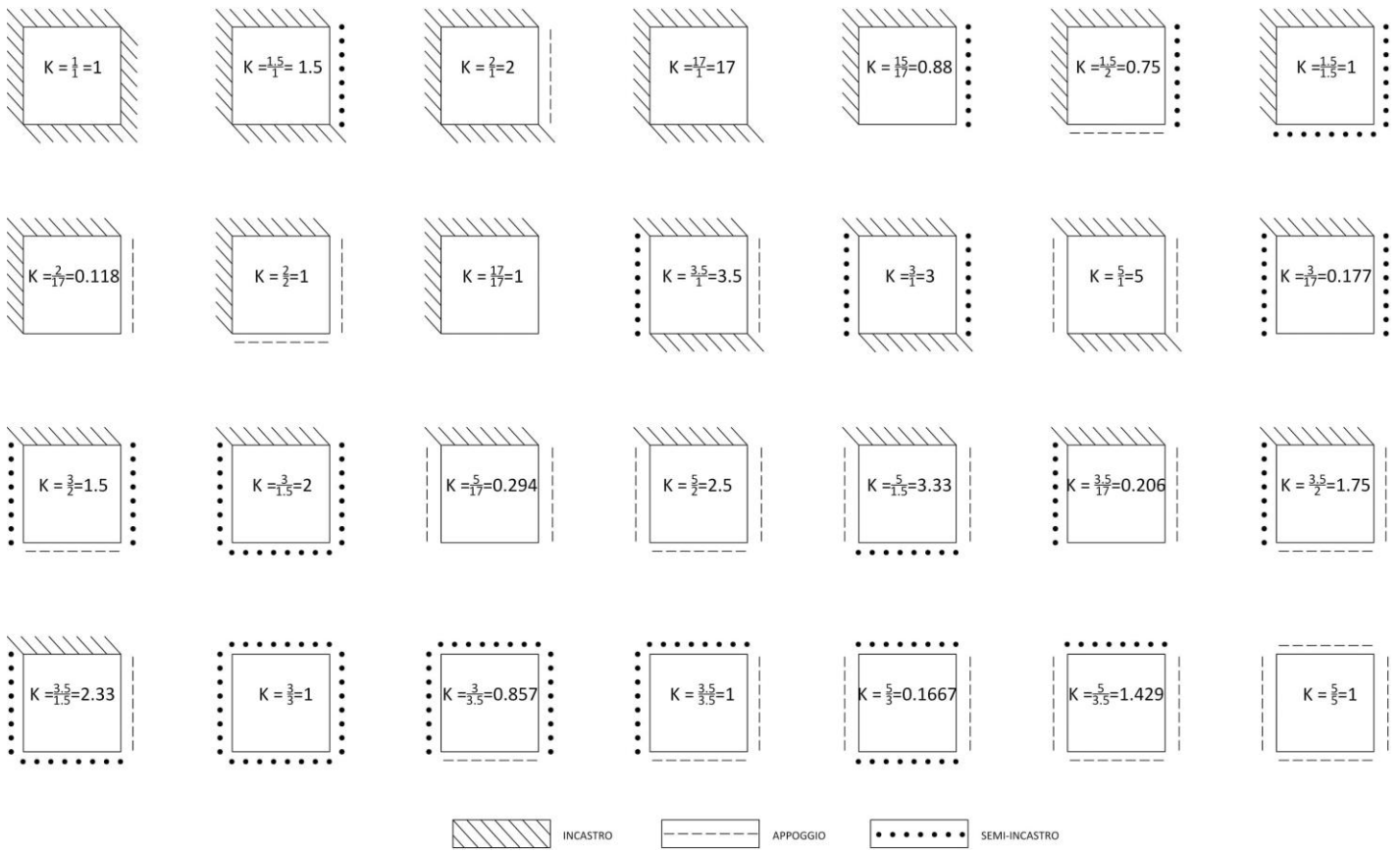

Figure 17 - constraint schemes

3.3.3 F.E.M. modeling

It is possible to shape the finite concrete lightened plate with **New Nautilus EVO** elements, as full plates with reduced values of stiffness and mass. You can adopt one of the following solutions:

- shape the plate with **New Nautilus EVO** as a slab of the construction thickness, but with multiplicative coefficients for mass and inertia reduction;
- shape the plate with **New Nautilus EVO** as a full slab of reduced thickness, in order to obtain equivalent stiffness and weight;
- shape the plate with **New Nautilus EVO** as a slab of the construction thickness but introduce coefficients on the reinforced concrete material of the portion of the plate occupied by the lightening, in order to reduce the Young's modulus and self-weight.

The solution **a** is obtained as follows:
remembering that the flexural stiffness value D is:

$$D = \frac{E \cdot I}{(1 - \nu^2)}$$

Where:

- E is Young's Module;
- I is the Moment of Inertia;
- ν is the Poisson's Module.

Our goal is to shape an isotropic plate to the finite elements, with the same stiffness as a light plate:

$$D_{full} = D_{void}$$

$$\frac{E_{full} \cdot I_{full}}{(1 - \nu^2)} = \frac{E_{void} \cdot I_{void}}{(1 - \nu^2)}$$

$$R_f = \frac{E_{void} \cdot I_{void}}{E_{full} \cdot I_{full}}$$

The coefficient R obtained is the reductive coefficient to be applied to a full plate in the program with finite elements in order to obtain the equivalent flexural stiffness of the plate with **New Nautilus EVO**, and, if the material is the same, it becomes:

$$R_f = \frac{I_{void}}{I_{full}} < 1$$

CALCULATE THE INERTIA OF THE LIGHTENED SLAB

ELEMENT	INERTIA	BARYCENTER	AREA [mm ²]	VOLUME
S	[mm ⁴]	[mm]		[m ³]
H10	38577300	48.3	46361	0,024
H13	84834500	62.9	60350	0,028
H16	158272000	77.6	74339	0,032
H20	309335100	97.1	92909	0,039
H23	448121900	115.3	106712	0,052
H24	534784000	116.6	111643	0,046
H26	648180500	130.0	120701	0,056
H28	849526400	136.2	130295	0,053
H29	901349400	145.0	134690	0,060
H30	1002580000	151.2	139353	0,063
H32	1212130200	160.0	148600	0,064
H33	1332396800	165.8	153342	0,067
H34	1465266900	171.8	158004	0,070
H36	1729333800	180.5	167331	0,071
H37	1883915700	186.3	171994	0,074
H38	2052377400	192.2	176649	0,077
H40	2373891500	200.0	185982	0,078
H41	2570833000	206.8	190645	0,081
H44	3163889700	220.0	204635	0,085
H48	4109701700	240.0	223200	0,092
H52	5230090000	260.5	241938	0,099
H56	6534840000	280.0	280590	0,106

Therefore, the inertia of the lightened rib can be found, using Huygens-Steiner, as:

$$I_{x/y}^{void} = \frac{1}{12} B_t \cdot H_t^3 + B_t \cdot H_t \left(\frac{H_t}{2} - y_G^{void} \right)^2 - I_{x/y}^{naut} - A_{naut} \cdot \left[\left(y_G^{naut} + S_i \right) - y_G^{void} \right]^2$$

- ◆ H_t : total thickness of the slab;
- ◆ B_t : interaxial spacing between the ribs;
- ◆ y_G^{void} : barycenter of the final lightened section;
- ◆ y_G^{naut} : barycenter of the empty zone;
- ◆ $I_{x/y}^{void}$: moment of inertia in the x or y direction of the final lightened section;
- ◆ $I_{x/y}^{naut}$: moment of inertia in the x or y direction of the empty zone;
- ◆ A_{naut} : surface of the empty zone.

Dividing the obtained quantity by the length of the interaxial spacing between the formworks, we find the inertia value per linear meter. While the inertia (per linear meter) of the solid section can be calculated as that of a rectangle of height equal to the height of the concrete section, and of width equal to the width of an element **New Nautilus EVO**, plus the size of the rib, the equivalent quantity for a lightened slab can be calculated as that of an **I** profile, with lower and upper wings given by the slabs, and a core with dimensions of the rib. The solution **b** is obtained by finding a thickness of a full plate, that has the same flexural stiffens of the lightened plate:

$$S_t = \frac{E \cdot I_{void}}{(1 - \nu^2)} = \frac{E \cdot H_t^3}{12 \cdot (1 - \nu^2)}$$

Resolving it, gives the expression of the fictitious thickness:

$$H_f = \sqrt[3]{12 \cdot I_{void}}$$

In a completely similar way to the one done for flexural stiffens, torsional and shear stiffens also must be reduced in order to shape the behavior of the lightened plate correctly

$$R_t = \frac{S_{t,void}}{S_{t,full}} < 1$$

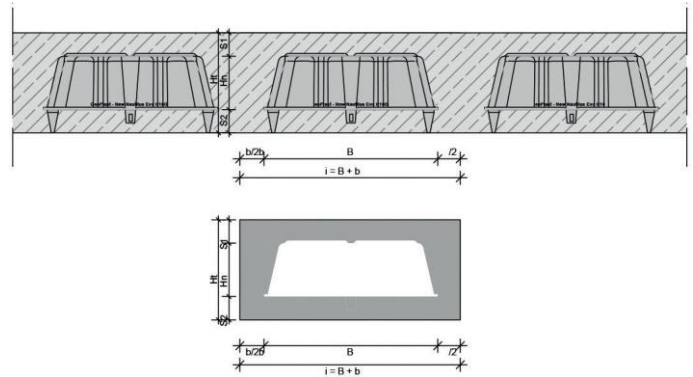

Figure 18 - section type - calculation of the reduction coefficients

The torsional stiffness of the full slab is determined according to the formula:

$$I_t = \alpha \cdot H_{tot}^3 \cdot i$$

Where the factor α is a function of the relation: i/H_{tot} :

i/H_{tot}	1.5	2.0	3.0	4.0
α	0,196	0,229	0,263	0,281

i/H_{tot}	6.0	8.0	10.0	∞
α	0,299	0,307	0,313	0,333

Similarly, it can be obtained for the lightened slab, using the Bredt's formula:

$$t_1 = \frac{N_{x/y}}{2}$$

$$t_2 = S_s$$

$$t_3 = S_i$$

$$b_k = i - T_1$$

$$d_k = H_t - \frac{S_s}{2} - \frac{S_i}{2}$$

$$I_t^{void,x/y} = \frac{4 \cdot b_k \cdot d_k}{\frac{2}{b_k \cdot t_1} + \frac{1}{d_k \cdot t_2} + \frac{1}{d_k \cdot t_3}}$$

So, the reduction factor turns out to be:
reduction

$$R_t = \min \left\{ \frac{I_t^{void,x}}{I_t^{full}}; \frac{I_t^{void,y}}{I_t^{full}} \right\} < 1$$

The multiplicative factor that takes into account the

of the shear strength is obtained by comparing the areas resistant to the shear stress of the full slab and the rib of the lightened slab:

$$R_s = \frac{A_{s,void}}{A_{s,full}} < 1$$

While a portion of unitary width of full slab reacts entirely to the shear, the shear area of the lightened slab is given only by the full area of the section.

Regarding the weight of the lightened slab itself, this can be calculated by subtracting the volume of the **New Nautilus EVO** formwork per square meter, from the weight of the corresponding full slab:

$$W_{void} = \left[H_{tot} - \frac{1}{(52 \text{ cm} + B)^2} \cdot Vol_{Naut} \right] \cdot \gamma_{cls}$$

This value allows you to find the reduction factor of the self- weight

$$R_w = \frac{W_{void}}{W_{full}} < 1$$

3.3.4 Practical example

Let's imagine that we need to perform the predimensioning of the following slab field:

- ◆ $L_x = L_y = 8 \text{ m}$
- ◆ $G_{k2} = 2 \text{ kN/m}^2$
- ◆ $Q_{k1} = 5 \text{ kN/m}^2$
- Concrete: strength class C32 / 40

From the estimates of predimensioning we can assume that the lightened slab should have a thickness equal to:

$$H_{tot} = \frac{L}{28} = 29 \text{ cm}$$

Potentially refined later, once our F.E.M. calculation model was created.

Let us assume that we perform reinforcement with the base mesh of $\varnothing 8 \text{ 20x20}$, with a concrete cover of 30 mm, the slab must be of a size such that can accommodate two diameters of the base mesh, the concrete cover, plus a distance diameter between the base mesh and the lightning element:

$$S_{min} = c + 2 \cdot \varphi + \varphi = 30 \text{ mm} + 2 \cdot 8 \text{ mm} + 8 \text{ mm} = 54 \text{ mm}$$

Rounded up, the minimum size for the lower and upper slabs is 60 mm. Therefore:

$$H_{min} = 29 \text{ cm} - 12 \text{ cm} = 17 \text{ cm}$$

Since the 17 cm lightning does not exist in the catalog, let's suppose that we are using the **New Nautilus EVO H16** lightning. In order to have a total thickness of 29 cm, it should be proceeded with the acquiring of 7 cm of lower slab and 6 cm of upper slab; in fact, it is preferable to use the larger of the two thicknesses in the lower slab, so as to ensure greater coverage of the reinforcing bars, with a resulting improvement of fire performance.

Again, as a first estimate, we can assume an interaxial spacing of 14 cm, and, if this is not sufficient, the thickness will be increased. In this case we will have a maximum theoretical impact of lightning equal to:

$$i = \frac{1}{(0.52 + 0.14)^2} = 2.30 \text{ casseri/m}^2$$

The weight of the plate will therefore be:

$$G_{kl} = \left(0.29 \frac{\text{m}^3}{\text{m}^2} - 2.30 \frac{\text{pz}}{\text{m}^2} \cdot 0.032 \frac{\text{m}^3}{\text{pz}} \right) \cdot 25 \frac{\text{kN}}{\text{m}^3} = 5.41 \frac{\text{kN}}{\text{m}^2}$$

This self-weight value will not be the correct one as it does not consider the full areas, however, we can use it as a first estimate.

At this point we can calculate the minimum size of the capital required:

$$p = 1.3 \cdot G_{kl} + 1.5 + G_{k2} \cdot 1.5 \cdot Q_{k1} = 17.55 \text{ kN/m}^2$$

$$\beta = 1.15 \text{ (pilastro centrale)}$$

$$v_{Rd,c} = 0.51 \text{ MPa}$$

$$d = H_{tot} - c = 29 \text{ cm} - 3 \text{ cm} = 26 \text{ cm}$$

$$V_{Ed} = 17.55 \frac{\text{kN}}{\text{m}^2} \cdot 64 \text{ m}^2 = 1123.2 \text{ kN}$$

Value obtained by multiplying the ultimate load by the area of influence of a central pillar

$$u_{out} = \frac{\beta \cdot V_{ed}}{v_{Rd,c} \cdot d} = 9.74 \text{ m}$$

This means that at least one area circumscribed by a circumference of diameter should be left around the pillar without any lightning.

$$D_{cap} = u_{out} / \pi = 3.10 \text{ m}$$

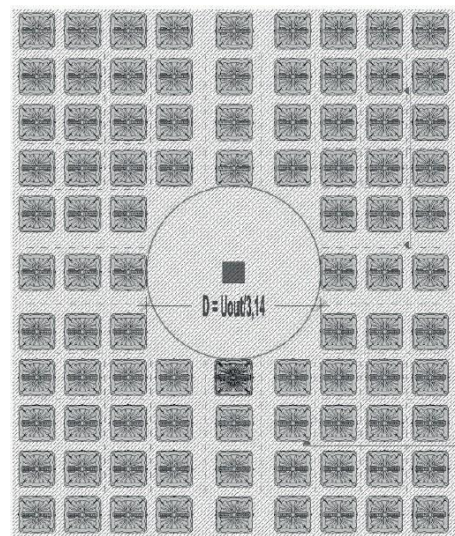

Figure 19 - critical per meter and area without lightning

If, on the other hand, our intent is to find the size of the capital such as to avoid having to insert shear reinforcement, the calculation is the following (as already explained above):

$$c^2 \cdot [p] + c \cdot \left[\frac{4 \cdot V_{Rd,c}}{i} \right] - p \cdot L_x \cdot L_y = 0$$

Where:

$$i = 0.66 \text{ m}$$

$$V_{Rd,c} = 18.03 \text{ kN}$$

Resolving it, gives the maximum size of the capital:

$$c = 5.49 \text{ m}$$

We can then proceed, having defined the geometry of the deck, with the creation of the model for the finite elements.

Taking into consideration that the minimum estimated capital is 3.10 m wide, assuming the elimination above the pillar of a whole number of lightening, it shall be taken a minimum capital equal to:

$$C_{reale} = 5 \cdot 0.66 + 0.14 = 3.44 \text{ m}$$

At this point we can calculate a self-weight in a more precise way:

1. The total reference surface is equal to:

$$8 \text{ m} \cdot 8 \text{ m} = 64 \text{ m}^2$$

2. The area without lightening will be equal to:

$$3.44 \text{ m} \cdot 3.44 \text{ m} = 11.83 \text{ m}^2$$

3. The net lightened surface will therefore be:

$$64 - 11.83 = 52.17 \text{ m}^2$$

4. The weight of the massive slab will therefore be:

$$0.29 \text{ m}^3/\text{m}^2 \cdot 25 \text{ kN}/\text{m}^3 = 7.25 \text{ kN}/\text{m}^2$$

The average weight of the plate will therefore be:

$$G_{kl} = \frac{7.25 \text{ kN}/\text{m}^2 \cdot 11.83 \text{ m}^2 + 5.41 \text{ kN}/\text{m}^2 \cdot 52.17 \text{ m}^2}{11.83 \text{ m}^2 + 52.17 \text{ m}^2} = 5.75 \frac{\text{kN}}{\text{m}^2}$$

It is possible to notice that compared to the initial estimate, the actual effective weight differs by approximately 6%, therefore, an acceptable inaccuracy. In this phase, however, the minimum capital requirements must be combined, with the convenience of maximum lightening, respecting minimum footing distances from the edge of the plate (in the order of 30-40 cm).

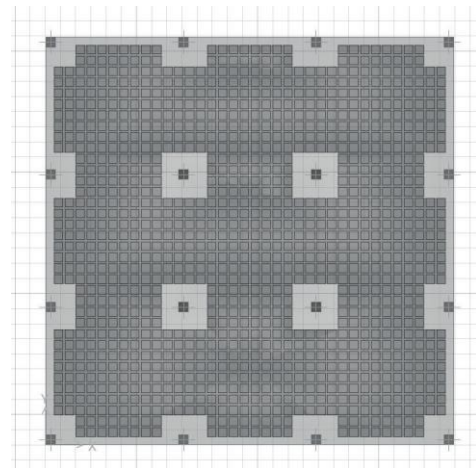

Figure 20 - FEM model, 2D.

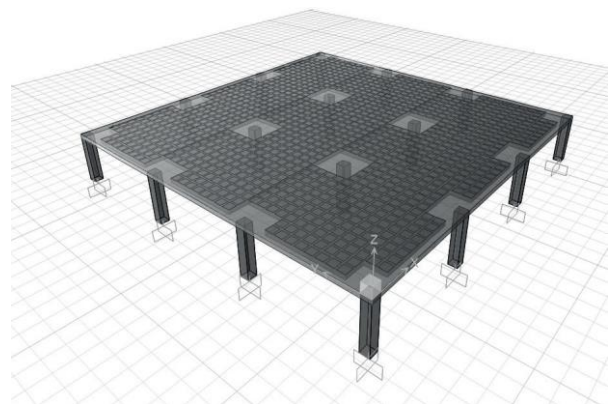

Figure 21 - FEM model, 3D.

$$R_{M,11} = 0.88$$

$$R_{M,22} = 0.88$$

$$R_{M,12} = 0.73$$

$$R_{T,13} = 0.61$$

$$R_{T,23} = 0.61$$

$$R_{MASS} = 0.75$$

3.4 Verification

3.4.1 Calculation of flexural reinforcements

the calculation is made in the assumption that in the presence of the last loads the reinforcement, in the two directions x and y , develops its own last resistant moments:

$$m_{xu} = z_x \cdot f_{yd} \cdot A_x \approx 0.9 \cdot d_x \cdot f_{yd} \cdot A_x$$

$$m_{yu} = z_y \cdot f_{yd} \cdot A_y \approx 0.9 \cdot d_y \cdot f_{yd} \cdot A_y$$

The assumption of simultaneous development of ultimate resistant moments implies infinite ductility of the reinforcing bars, therefore the elastic behavior is negligible; furthermore, the congruence between the extensions of the two bar families may not be considered, since the concrete cracks under tension and is not considered as a constraint for the reinforcement.

The following is the method of the normal moment, used for the local dimensioning of the reinforcement failure: therefore it is different from other methods, so called global methods, in which the reinforcement is sized and based on the behavior of the entire structure collapse (like the method of fault lines).

The last resistant moments developed by the reinforcement on a position having normal axis n and tangent axis t assume the following expressions:

$$m_{nu} = m_{xu} \cos^2 \theta + m_{yu} \sin^2 \theta$$

$$m_{tu} = m_{xu} \sin^2 \theta + m_{yu} \cos^2 \theta$$

$$m_{ntu} = (m_{xu} - m_{yu}) \cdot \sin \theta \cos \theta$$

It can be observed that a second member has no torque, since the bars are imagined as tensioned threads, together with the compressed concrete, the only resistant mechanism that the reinforcement develops is bending.

For any position, and for any orientation of n , the calculation of the reinforcement must comply with the following conditions:

$$M_n \leq m_{nu}$$

$$M_{nt} \leq m_{ntu}$$

It should be noted that, however, in the reinforced concrete, even cracked, there are various mechanisms that allow resistance to torsion:

- Dowel action developed by the reinforcement that is stretched in the cracked area;

- continuity of the material in the compressed zone;
- aggregate interlock of cracked sides.

Such mechanisms, although they are not being at the same time at the maximum of their actions, contribute to the satisfaction of the second written inequality.

The next step is to identify the most critical position, in correspondence of which here is the least distance between a resistant moment and an acting moment, which can be expressed as:

$$\frac{d}{d\theta} (m_{nu} - M_n) = 0 ; \frac{d^2}{d\theta^2} (m_{nu} - M_n) = 0$$

The optimal utilization of the resources of the section in question suggests imposing the equality between stress moment and resistant moment, that is:

$$m_{nu} (\theta_{cr}) - M_n (\theta_{cr}) = 0$$

The third equation is obtained by imposing that the previous equations are satisfied with the minimum amount of reinforcement:

$$\frac{d}{d\theta} (A_x + A_y)_{0cr} = 0 ; \frac{d^2}{d\theta^2} (A_x + A_y)_{0cr} = 0$$

However, remembering the definition of the resistant moments given at the beginning of the paragraph, there is a direct proportionality between the reinforcements and the mentioned moments:

$$\frac{d}{d\theta} (m_{xu} + m_{yu})_{0cr} = 0 ; \frac{d^2}{d\theta^2} (m_{xu} + m_{yu})_{0cr} = 0$$

Finally, it is noted that $m_{xu} + m_{yu} = m_{nu} + m_{tu}$ it is obtained:

$$\frac{d}{d\theta} (m_{nu} + m_{tu})_{0cr} = 0 ; \frac{d^2}{d\theta^2} (m_{nu} + m_{tu})_{0cr} = 0$$

It can be shown that, for, $M_x > 0, M_y > 0$ that is, at the lower stretched edge, the expressions for the reinforcement design occur in the following form:

$$m_{xu} = M_{xu} + |M_{xyu}|$$

$$m_{yu} = M_{yu} + |M_{xyu}|$$

And it entails the need to have a position of reinforcement that develops, in both directions, a positive resistant moment.

On the contrary, to determine the reinforcements on the upper edge (negative resistant moment), we have the following expressions:

$$m_{xu} = M_{xu} - |M_{xyu}|$$

$$m_{yu} = M_{yu} - |M_{xyu}|$$

The mathematical model just illustrated corresponds to a precise physical model, with the formation of a framework of ties (reinforcing bars) and struts, on the stretched edge.

The resolving expressions that are found must be applied jointly in every point of the structure: there are indeed points in which there is a weak flexion and a strong torsion, and that is until the following inequalities are verified:

$$|M_{xu}| < |M_{xyu}|$$

$$|M_{yu}| < |M_{xyu}|$$

In this case the stretched reinforcements are required by the twisting stress.

3.4.2 Calculation of the reinforcements strip method

3.4.2a Calculation of bending moments

Within the Static Method, the ultimate limit state of a plate is characterized by the achievement of the limit moment in one or more sections.

Therefore, the range of moments must obey the equation of the flexural equilibrium of the plate:

$$\frac{\partial^2 M_x}{\partial x^2} + 2 \cdot \frac{\partial^2 M_{xy}}{\partial x \cdot \partial y} + \frac{\partial^2 M_y}{\partial y^2} = -p(x, y)$$

There are a priori infinite moment fields able to satisfy this equation, but there is only one exact solution, corresponding to the formation of the kinematics.

With the exception of a limited number of simple cases, it is practically impossible to determine the exact solution without the use of automatic calculation. However, it is possible to obtain satisfactory solutions, even if approximate, regardless of the formation of a mechanism, as proposed for example by Hillerborg, whose Strip Method is easy to use.

This method disregards the torsion, so the equation of equilibrium becomes:

$$\frac{\partial^2 M_x}{\partial x^2} + \frac{\partial^2 M_y}{\partial y^2} = -p(x, y)$$

In the slotted plate there are at least three torsion-resistant mechanisms, and therefore, in principle, the torsion cannot be ignored. However, when the reinforcement is being sized (objective of the Hillerborg method), it is cautious not to take into account the torsion as the three mechanisms mentioned above (torsion in the compressed zone, aggregate mashing in the slotted plates and wedge action of the reinforcements) too often depend on factors that are not part of the designer's control, such as the extension of the compressed zone, the opening of the slots and the local flexural stiffness of the reinforcement.

This hypothesis of neglected torsion corresponds to a hypothesis of a mechanical model including the plate made of a set of strips arranged in the x and y directions, each subject to bending and shearing.

Therefore, the strips arranged along the line x absorb a part of the load, $\alpha \cdot p$ and the strips in the y direction - the remaining part $(1 - \alpha) \cdot p$; this can be translated with the equations :

$$\frac{\partial^2 M_x}{\partial x^2} = -\alpha \cdot p_u$$

$$\frac{\partial^2 M_y}{\partial y^2} = -(1 - \alpha) \cdot p_u$$

For practical reasons, variable values cannot be assigned to the coefficient with continuity, but constant values in zones. The plate must therefore be divided into zones, each with its own value of α . The choice of this value must be made on the basis of the most effective flexion in the transmission of the boundary load, according to the following criteria: Since two bent strips intersect in each dx dy areola of the plate, one parallel to the x axis and the other parallel to the y axis, the load acting on that areola is transmitted to the boundary mainly by the strip that is more rigid during flexion (with less span, and/or with more rigid end constraints and/or connecting the areola with the nearest constraint); therefore, in the transmission of the load to the boundary, prevails the direction $x(1 \rightarrow \alpha)$ or direction $y(\alpha \rightarrow 0)$ depending on whether the strip aligned with x or the strip aligned with y is locally more rigid.

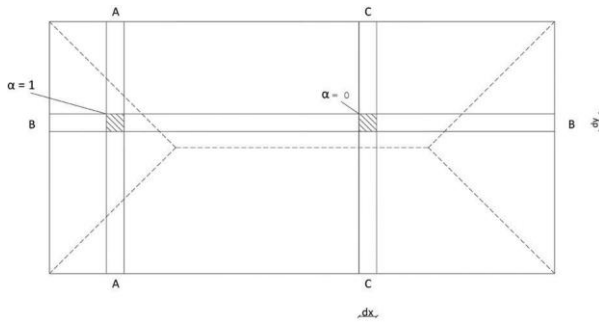

Figure 22 - representation of the strip method according to Hillerborg

In details:

- Plate uniformly constrained to the boundary: to the areas closest to the sides aligned with the y axis higher values of α must be assigned (between 0.5 and 1), while to the areas closest to the sides aligned with the x axis, small values of α must be assigned (between 0 and 0.5) figure A.
- For zones that are have the same average distance between two equally bound sides, it is also reasonable to set $\alpha = 0.5$ and to adopt a distribution as in figure B.

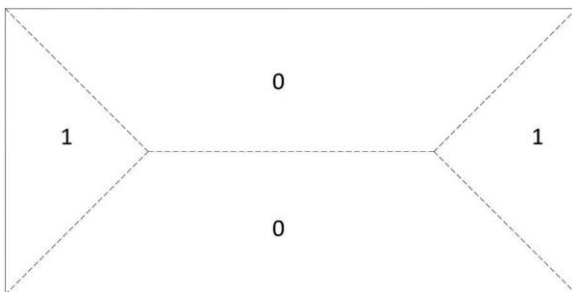

Figure 23 - possible distribution (A) in a rectangular plate leaning on the boundary

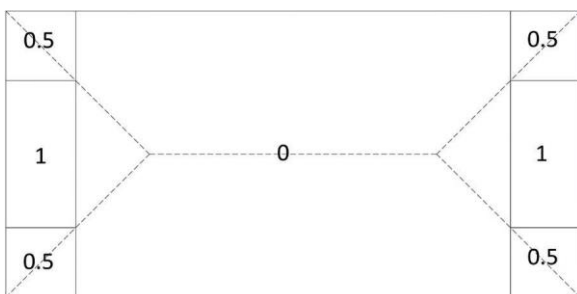

Figure 24 - possible distribution (B) in a rectangular plate leaning on the boundary

- Plate with constraints to mixed boundaries: the proximity to a joint aligned with y results in larger values of α , while the proximity to a free edge aligned with y results in a null value of α . Since it is not possible (due to lack of constraint and structural continuity) any load transmission in the x direction (orthogonal to the edge itself).

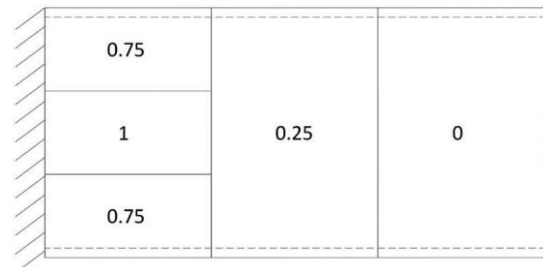

Figure 25 - possible redistribution in a rectangular plate with constraints to mixed

The strip method also gives reason for the so-called "handles", which are boundary areas for the slots, and act as real support beams for the strips that are orthogonal to them and that are interrupted by the presence of the slot.

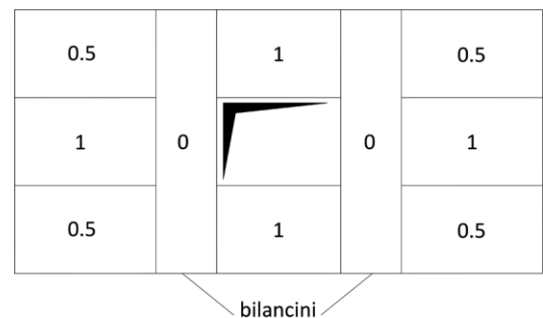

Figure 26 - example of plate with slot and handles (assigned geometric dimensions)

In each strip the reinforcement must be sized based on the maximum moment (the sizing is conservative):

$$m_{xu} = m_{xu}(\alpha, p_u, P_u)$$

or

$$m_{yu} = m_{yu}(1 - \alpha, p_u, P_u)$$

It Once the stress moments, calculations and verification of reinforcement can be done with the usual failure method on the design section qualitatively illustrated in the figure bellow.

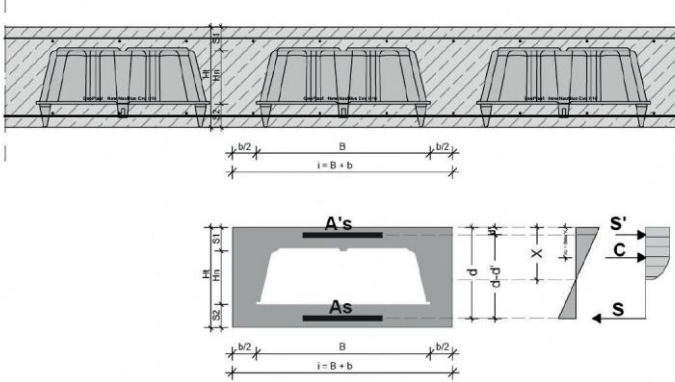

Fig. 23 shows the seasonal use for calculating the failure method

3.3.1 Calculation and verification of shear reinforcements

Upon extraction of the value of the stressed shear action, from abacus or from analysis of finite elements, the calculation of the shear reinforcement can be obtained through the same procedure applied to an I profile.

The rib resistance in the absence of transverse reinforcement is calculated in the following way:

$$V_{Rd,c} = \frac{0.18}{\gamma_c} \cdot (100 \cdot \rho_l \cdot f_{ck})^{1/3} \cdot \left(1 + \left(\frac{200}{d}\right)^{1/2}\right) \cdot b_w \cdot d$$

Where:

The terms that appear in this equation are:

- ◆ f_{ck} is the characteristic strength of concrete, expressed in Mega Pascal;
- the percentage of stretched reinforcement, ready to resist bending is:

$$\rho_l = \frac{A_{st}}{b_w \cdot d} \leq 0.02$$

As this value increases, the resistance to shearing increases, due to the increase in the meshing effect;

- the term

$$\left(1 + \left(\frac{200}{d}\right)^{1/2}\right)$$

takes into account the dimensional effect. In relation to the phenomena of brittle fracture, the plates of greater thickness have less resistance to punching per surface unit along the critical perimeter. This term cannot be greater than 2;

- $b_w \cdot d$ is the shear-resistant area, where the first term is the width of the joist's core, while the second is the useful height.

The Eurocode (6.2.1 (4)) says that:

"If, on the basis of the shear design calculations, no shear reinforcement is required, it is recommended to use at least a minimum reinforcement according to **point 9.2.2**.

This minimum reinforcement can be omitted in elements such as slabs (full, ribbed, hollow) where the transverse distribution of loads can occur. [...]"

In areas where the shear exceeds the resistant shear of the concrete, it is necessary to insert a shear reinforcement.

The design of elements with shear reinforcement is based on a truss model, and, for elements with vertical shear reinforcement, shear strength is defined as:

$$V_{Rd} = \min \{ V_{Rd,s}; V_{Rd,c} \}$$

Where:

$$V_{Rd,s} = \frac{A_{sw}}{s} \cdot z \cdot f_{ywd} \cot \theta$$

The terms that appear in this equation are:

- ◆ A_{sw} , cross section area of the shear reinforcement;
- s , the tie pitch;
- ◆ f_{ywd} , the yield stress of the shear reinforcement design;
- it is recommended for the θ angle, which represents the angle of inclination of the concrete strut compared the axis of the beam, to be limited: $1 \leq \cot \theta \leq 2.5$
It should be remembered that setting the maximum value corresponds to finding the minimum amount of reinforcement necessary to satisfy a given request for shear action.
- z it is the internal lever arm, for an element of constant height, corresponding to the maximum bending moment in the considered element.

While the maximum strength of the concrete is:

$$V_{Rd,max} = \alpha_{cw} \cdot b_w \cdot z \cdot v_1 \cdot f_{cd} / (\cot \theta + \tan \theta)$$

Where:

- ◆ v_1 is a coefficient for reduction of the concrete strength cracked due to shear, the value of which can be found in the Eurocode national appendix, while its recommended value is:

$$v_1 = v = 0.6 \cdot \left[1 - \frac{f_{ck}}{250}\right] \left(\text{con } f_{ck} \text{ in } M Pa\right)$$

- ◆ α_{cw} is a coefficient that takes into account the interaction between the tension in the current stress and any axial compression tension. Its value is unitary for non-prestressed structures.

In a more general situation in which the shear reinforcement is inserted at an angle, the shear strength is equal to the lowest value between:

$$V_{Rd,s} = \frac{A_{sw}}{s} \cdot z \cdot f_{ywd} \cdot (\cot \theta + \cot \alpha) \sin \alpha$$

$$V_{Rd,max} = \alpha_{cw} \cdot b_w \cdot z \cdot v_1 \cdot f_{cd} \cdot (\cot \theta + \tan \theta) / (1 + \cot^2 \theta)$$

3.3.2 Types of transverse reinforcements

There are various types of transverse reinforcement in use: shear studs, shear hooks, closed ties; these construction details can also be found in "Fib Bulletin 2: Structural Concrete "

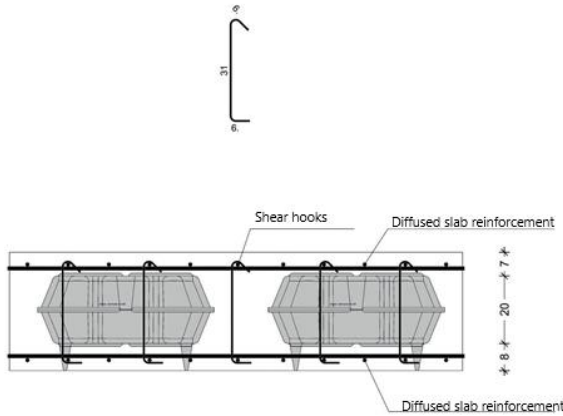

Figure 28 - shear-resistant hooks

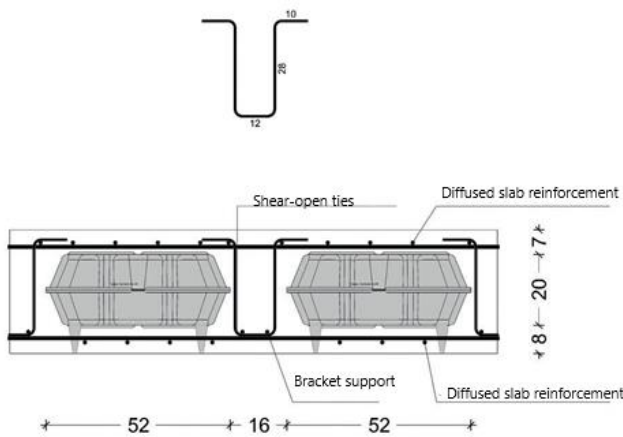

Figure 29 - shear-resistant open ties

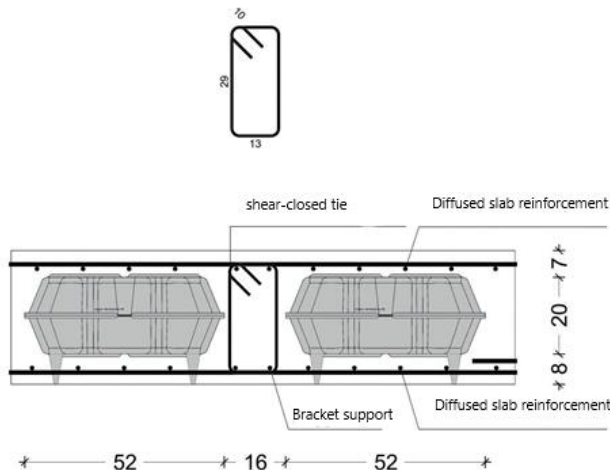

Figure 30 - shear-resistant hooks

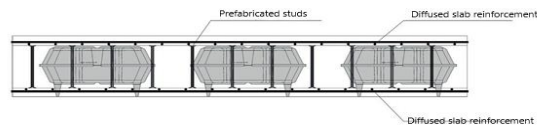

Figure 31 - shear-resistant prefabricated pins

3.3.3 Verification of the interface between concrete layers cast at different times

The value of the stressed slip force generated between layers of concrete cast at different times can be estimated with reference to EC2 par. 6.2.5:

$$v_{Edi} = \frac{\beta \cdot V_{Ed}}{Z \cdot b_i}$$

Where:

- ◆ β is the ratio between the longitudinal force in the last concrete casting and the total longitudinal force in the compressed or stretched area, both calculated in the considered section;
- ◆ V_{Ed} is the transverse shear force;
- Z it is the internal lever arm; ($\sim 0,9 \cdot d$)
- ◆ b_i is the width of the interface (in our case equal to the interaxial spacing between the lightning);

The shear resistance of the interface design is given by:

$$v_{Rdi} = c \cdot f_{ctd} + \mu \cdot \sigma_n + \rho \cdot f_{yd} \cdot (\mu \cdot \sin \alpha + \cos \alpha) \leq 0,5 \cdot v \cdot f_{cd}$$

Where:

- ◆ $C = 0,40$
- ◆ $\mu = 0,7$
- ◆ f_{ctd} tensile strength of the concrete design
- ◆ σ_n tension produced by the minimum external force acting in the interface that can act simultaneously with the shear force, positive if from tensioning, but such that $\sigma_n < 0,6 \cdot f_{cd}$ is negative if from tension. If σ_n is from traction it is recommended to assume $c \cdot f_{ctd}$ equal to 0;
- $\rho = A_s / A_i$ ratio between the reinforcement area that crosses the interface and the area of the interface;
- v coefficient of reduction of the resistance referred to in paragraph 6.2.2 (6);

- σ is a factor, which considers the indented construction joint such that $45^\circ \leq \alpha \leq 90^\circ$

Check that v_{Edi} it is less than v_{Rdi} .

Regulatory requirements

In full, ribbed, or lightened slab, it is not necessary to place minimum shear reinforcement where the transverse distribution of the load is possible, as reported in the Eurocode in point 6.2.1 (4):

“If, based on the shear design calculations, no shear reinforcement is required, it is recommended that there should still be a minimum reinforcement according to point 9.2.2. This minimum reinforcement can be omitted in elements such as slabs (full, ribbed, hollow) where the transverse distribution of loads can occur.”

The same approach can be found in the British regulation BS8110 1997, Structural use of concrete - Part 1: Code of practice for design and construction at the point

3.6 Ribbed slabs (with solid or hollow blocks or voids).

Have an idea of the distance in which the shear reinforcement is inserted

In the previous paragraph it was calculated how much reinforcement is necessary to withstand the maximum shear stress, however, it is not necessary for this quantity to be re-proposed on all the lightened spans, in fact the shear, far from the supports, decreases in value, until being possible to be

supported solely by the contribution of concrete. If you want to have an indicative idea of what is the distance within which the reinforcement must necessarily be placed, the following reasoning can be followed:

Let's consider a slab consisting of an infinite series of fields, with spans in the two directions L_x and L_y , let's analyze a pillar; that pillar will have a capital with the dimensions C_x C_y . Imagining that the shear on the plate varies linearly with the load p , the action will have a maximum value in correspondence with the pillar (with value $p \cdot L_{x/y}$, given that we have two slab fields that discharge on the pillar), and it will cancel itself in correspondence with the midspan section.

If the objective is to find the distance from the pillar beyond which the shear reinforcement is no longer necessary, with a simple triangular proportion we have:

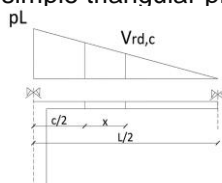

Figure 32 - distance calculation x

$$\frac{L_{x/y}}{2} : p \cdot L_{x/y} = \left(\frac{L_{x/y}}{2} - \frac{c_{x/y}}{2} - x \right) : V_{Rd}$$

$$\frac{L_{x/y}/2}{p \cdot L_{x/y}} = \frac{\left(\frac{L_{x/y}}{2} - \frac{c_{x/y}}{2} - x \right)}{V_{Rd}}$$

$$x = \frac{L_{x/y}}{2} - \frac{c_{x/y}}{2} - \frac{V_{Rd}}{2p}$$

Obviously, this is only a control of the first approximation and is not intended as a regulatory constraint.

3.4.6 Calculation and verification to punching

Shear forces are often dominant factors in the behavior of the plates, which strongly influence the design. The shear forces are the biggest in correspondence to the pillars or to other supports or concentrated loads, or when the introduction of forces concentrated in the transverse direction to in- plane of a plate occurs.

If we consider a plate resting on pillars, the reaction transmitted by the pillar must be distributed in the concrete at the interface between the plate and the pillar; there are considerable shear stresses, as well as very high negative moments, and consequently a considerable concentration of stresses. This can cause a sudden break due to penetration throughout the plate, with the formation of diagonal cracks that cross the thickness of the concrete. This phenomenon is named punching failure.

Initially it manifests itself with the opening of circular cracks around the head of the pillar; these are followed by the cracks opening in the radial direction starting from the pillar; at about 2/3 of the breaking load the opening of truncated cone-shaped cracks occurs, from the low part of the interface between the pillar and the plate towards outside; as the load increases, the crack is suddenly reached with an abrupt increase of the width of the truncated cone-shaped cracks, without any warning in terms of deformations.

The presence of flexural reinforcement increases the punching resistance. In some cases, a too low bending percentage of flexural reinforcement above the columns can contribute to failure; it is therefore necessary to size the reinforcement in these areas also in regard to the danger of punching failure, as well as of bending stresses.

Based on these observations it is possible to schematize the punching phenomenon in different ways:

- consider the equilibrium in conditions of failure between the stress at the base of the cone and the tractive force in the upper reinforcements that are ready to absorb the corresponding bending moments;
- representing the resistant mechanism by a truss with compressed concrete struts and rods stretched due to the resistant contribution of tractive concrete and of the reinforcements arranged to contrast the opening of the diagonal cracks.

It is necessary to carefully check that the safety conditions are respected, due to the fragile nature of the phenomenon, which does not ensure any warning on plate failure. Punching in extreme conditions can cause a deck to fall on the underlying one, triggering its fall with a knock-on effect and starting an incremental failure. In order to avoid the risk of the aforementioned brittle failures, particular reinforcements are provided, so called punching reinforcements, which pass through the breaking cone vertically in order to absorb the tensile stress through the crack; from the static point of view they play the role of extended connecting rods in the truss scheme. In order to perform this function, the transverse reinforcements must be adequately anchored. If classic ties are used, they must be connected to the flexural reinforcement which therefore also acts as a tie holder. This type of solution is possible in plates and foundations of average thickness, if the thickness is small, it is necessary to use special devices, for example systems consisting of short transverse bars equipped with anchor plates to be placed in the pour and run parallel to the middle plain, or by creating reinforcing baskets made of weaving bars that are transverse and parallel to the support surface.

Calculation model - verification of the resistance on the critical perimeter

Given the complexity of the failure phenomenon due to punching, the standards acquire simplified verification procedures, defining a verification surface in the thickness of the plate, orthogonal to the middle plane, at which the cutting stresses must not exceed a predetermined material strength value.

The surface defined by the EC2 is at a distance of twice the useful height of the plate. In this way a reference perimeter u is evaluated, which should be multiplied by the useful height d to obtain the reference surface. Obviously, the verification surface changes when the columns are placed at the edge or in a corner of the plate, or if there are openings in the plate which reduce the available surface, or when the effect of horizontal loads is sensitive.

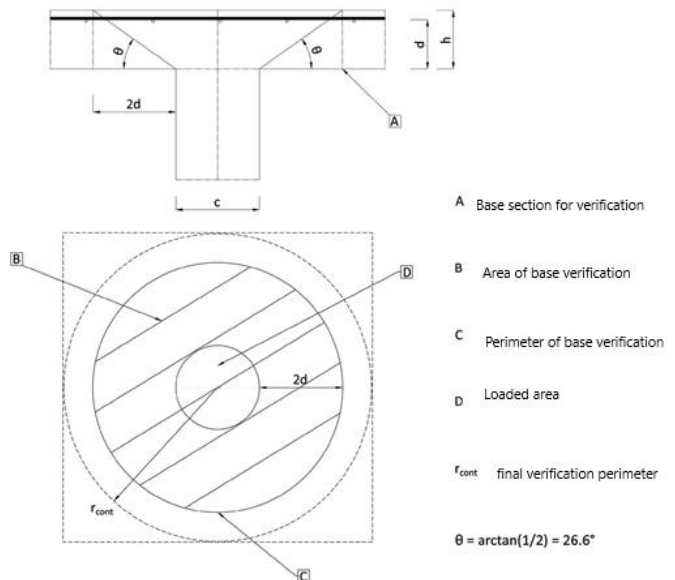

Figure 33 - punching

To simplify the calculation, Eurocode 2 proposes as the first simplified approach of the amplification coefficients of the average stress, that is obtained by uniform distribution of the transmitted action from the pillar to the verification surface.

The stress can therefore be calculated as:

$$v_{sd} = \beta \frac{V_{sd}}{u \cdot d}$$

Where:

- ◆ V_{sd} is the calculation value of the total force of the acting shear;
- u is the perimeter of the critical section;
- ◆ β is the coefficient that considers the non-uniform distribution of stress.

The values of β are proposed by Eurocode 2 in different ways, depending on whether the structure in the presence of lateral loads relies on suitable bracing elements, or only on the stiffness of the plate-column assembly.

In the first case the coefficient β is:

- ◆ $\beta = 1.15$ for internal pillar;
- ◆ $\beta = 1.4$ for lateral pillar;
- ◆ $\beta = 1.5$ corner pillar.

Punching resistance

The choice of the reference surface is not very equivalent to the actual failure mode. However, some elements that correspond to the physical reality are introduced into the verification, one linked to the strength of the material, a contribution from punching reinforcements, and finally one owed to the presence of reinforcements provided for bending.

In case of given punching stress V_{sd} equal to the reaction of the column, and a strength V_{Rd} , the stress and strength values, dimensionally stresses, v_{sd} v_{Rd} are calculated by dividing these actions by the area of the reference surface, equal to $u \cdot d$

The resistance of the material to the punching is obtained by the shear strength of the concrete increased with the multiplication by a coefficient k to take into account the beneficial effects of the meshing mechanism of the concrete along the diagonal crack.

An important contribution to the punching resistance is given by the stretched flexural reinforcement set at the top of the pillar, which, by passing through the cone shape cracking, acts as a support to the plate (with an effect similar to that of the reinforcement dowel in the shear failure of the beams). The verification formula takes into account the ρ_l medium reinforcement percentage, between the percentages in the two orthogonal directions.

The strength of concrete alone, in the absence of punching reinforcement, is defined as:

$$v_{Rd,c} = \frac{0.18}{\gamma_c} \cdot k \cdot (100 \cdot \rho_l \cdot f_{ck})^{1/3} \geq v_{min}$$

$$v_{min} = 0.035 \cdot k^{3/2} \cdot f_{ck}^{1/2}$$

Where:

- $k = 1 + \sqrt{\frac{200}{d}} \leq 2$ (with d in mm) coefficient that takes into account the meshing;
- $\rho_l = \rho_x \cdot \rho_y$ medium longitudinal reinforcement above the column;

It is recommended to take ρ_x, ρ_y as average values for the percentage of stressed reinforcement, adequately anchored, above the pillar, calculated in relation to a width equal to the transverse dimension of the column increased by $3d$ on each side.

In case the punching reinforcements are used:

$$v_{Rd,tot} = 0.75 \cdot v_{rdc} + 1.5 \cdot \left(\frac{d}{s_r}\right) \cdot A_{sw} \cdot f_{ywd,ef} \cdot \sin \alpha \cdot \left(\frac{1}{u \cdot d}\right)$$

The punching resistance offered by the concrete must also be checked immediately just before the pillar:

$$v_d = \beta \cdot \frac{V_d}{u_0 \cdot d} < v_{Rd,max} = 0.4 \cdot v \cdot f_{cd}$$

Where:

- ◆ V_d is the calculation value of the total force of the acting shear;
- ◆ u_0 is the perimeter of the critical section close to the pillar (various, depending on the pillar position);
- ◆ β is the coefficient that takes into account the stress distribution;
- $v = 0.6 \cdot \left[1 - \frac{f_{ck}}{250}\right] (MPa)$ takes into account the resistance of concrete cracked due to the shear.

3.4.7 Displacement control

The verification of the maximum displacements of a structure is essential to ensure the preservation of appearance and functionality requirements, avoiding damage to partitions, finishings and window and door frames.

In some cases, certain limits may be required to ensure the correct operation of machinery or installations supported by the structure, or water stagnation on the roof.

Finally, sometimes it is also necessary to impose limits from the point of view of vibrations, in order to avoid inconvenience to the inhabitants, or even structural damage.

The European legislation allows omitting of the calculation and verification of displacements, if the plate elements do not exceed a limit value of the ratio between span and thickness. When the structure is slimmer than these limits it is necessary to perform the calculation.

From a general point of view, the strict calculation of displacements occur through the integration of the curvatures of the element under the quasi-permanent load. For this purpose, for the calculation of the deflection, it is possible to apply substantially the same methods used for the beams, applied to a strip of plate along which the curvatures are evaluated.

Considering the response of a bent element, the presence of intact concrete areas and cracks is observable; in the calculation it is necessary to consider both the behavior of the fully reactive traction section (stage I - elastic), and of the partialized section, without concrete that reacts to traction (stage II - cracked), assessing in this way the greater deformability due to crack opening. It is therefore important to consider the percentage of reinforcement present in the sections and its tension commitment.

It is also necessary to take into account the increase in displacements due to viscous deformations. In this regard, permanent and almost permanent loads acting on the structure must be considered.

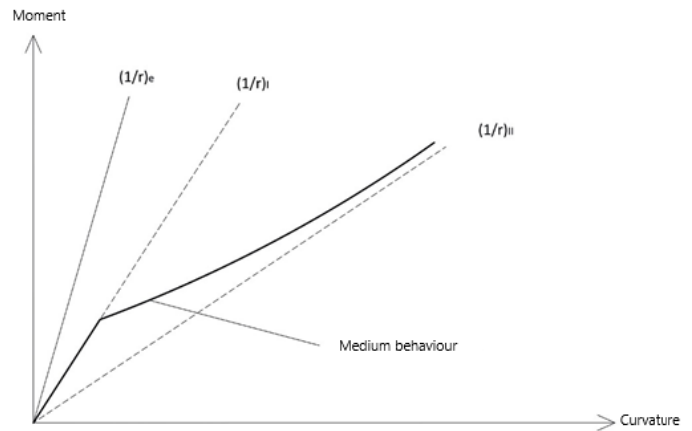

Figure 34 - moment-curvature relation "average" for the calculation of displacements

The moment-curvature relation defines the response in terms of deformation of the section for a given stress value. First, the linear elastic response is represented $(1/r)_e$ corresponding to a fully reactive section, without considering the cracking state. If the effects of viscosity are considered, always under the hypothesis of a fully reactive section, the straight line will be obtained.

$(1/r)_I$ Stage II, on the other hand, considers the fully cracked state. The global response can be assessed by defining an "average" behavior $(1/r)_m$ between these.

The average behavior is defined in Eurocode 2 and in the Italian legislation as:

$$(1/r)_m = (1 - \zeta) \cdot (1/r)_I + \zeta \cdot (1/r)_{II}$$

The distribution coefficient ζ is between 0 and 1 and increases with the increase of stress in the steel, which is evaluated in the calculation of the bent sections; for increasing values of the bending moment, the average behavior approaches the level $(1/r)_{II}$. From the physical point of view this reflects the progressive reduction of the stiffening effect given by the concrete with the increasing of the stresses and the opening of the cracks.

The formula to derive ζ is the following:

$$\zeta = 1 - \beta_1 \cdot \beta_2 \cdot \left(\frac{\sigma_{st}}{\sigma_s} \right)^2$$

- ◆ $\beta_1 = 1$ for bars with improved adherence, 0.5 for straight bars;
- ◆ $\beta_2 = 1$ for short-term load, 0.5 for permanent or cyclic loads;
- ◆ σ_{st} stress in the steel in stage II in correspondence with the cracking load;
- ◆ σ_s stress in the steel in stage II in correspondence with the acting load.

The quantity σ_{st}/σ_s can be replaced, as a first approximation, by M_{cr}/M_{medio}

The plates resting on pillars are economical constructions due to the small thickness of the structure and the simplicity of the construction. For this reason, the control of the deflections is particularly important.

In conditions of load and symmetrical constraints, the maximum deflection in the center of the field should not be taken into consideration in relation to the span measured in parallel to the sides of the plate, but relatively in relation to a span equal to the diagonal line of the plate.

As an alternative it is possible to take into consideration the relative displacement between the center of the plate and its edges (which will be smaller than the maximum displacement), relating to a span equal to the side of the plate. The maximum displacement on this strip corresponding to the median length is about 0.75 times the maximum deflection.

Finally, it is possible to measure the ratio between the maximum lowering on the line joining two pillars, and the span equal to the side of the plate. The maximum deflection for the plate strip on one side of the field is about 0.71 times the maximum deflection.

For the verification it is therefore appropriate and conceptually correct to use a ratio equal to $0.75 f_{max}/l$, less strict than f_{max}/l , since among the cases previously exhibited, the biggest ratio deflection-span is precisely $0.75 f_{max}/l$

3.5.7 Construction details

For the plates on pillars, the structural analysis with flat finite elements leads to evaluate bending and twisting moments with high values near the supports on the pillars or on walls. At the ultimate limit state, the use of the elastic method provides for the possibility of redistributing the internal actions, in order to take into account, the great internal hyperstaticity of the plate, which however is reduced by the progression of the concrete cracking and of the plasticization of the reinforcement. Eurocode 2, for the minimum and maximum amount of bending reinforcement, makes reference to the paragraph regarding the requirements for beams, but with the addition of requirements for transverse reinforcement; for unidirectional load bearing plates, in fact, it must be planned in a quantity not less than 20% of the main reinforcement area. Further prescriptions concern the maximum recommended S_{max} bar pitch:

- For main reinforcement, $3h < 400 \text{ mm}$, being h the total height of the plate;
- ◆ $3.5h < 450 \text{ mm}$ for secondary reinforcement.

In areas with concentrated loads or with maximum moment the previous values become respectively:

- For main reinforcement, $2h < 250 \text{ mm}$, being h the total height of the plate;
- For secondary reinforcement $3h < 400 \text{ mm}$.

At a free edge it is necessary to arrange reinforcement in a direction parallel and orthogonal to the same edge; for this purpose, the reinforcements calculated for the plate can be used, prepared to extend up to the edge and to create a C-shaped closing steel. This reinforcement effectively resists torsion, which is particularly high near the supports, and requires sufficient anchoring.

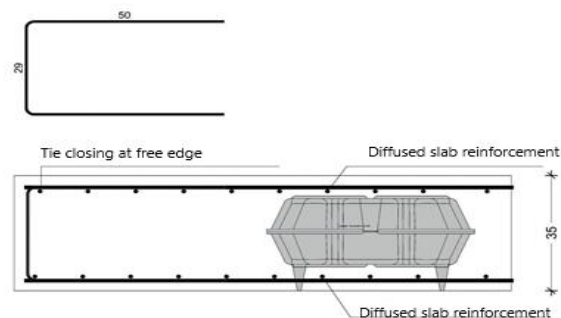

Figure 35 - detail of free edge closing reinforcement

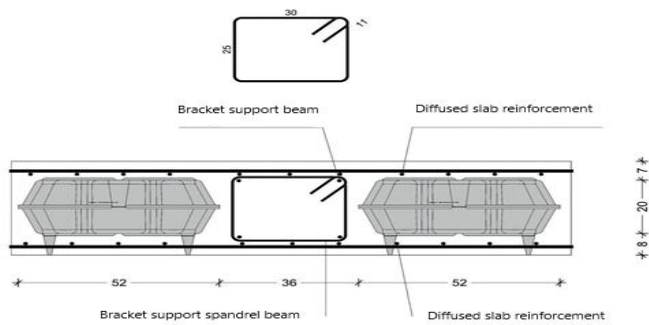

Figure 36 - constructive detail of lightening with stiffening spandrel beam

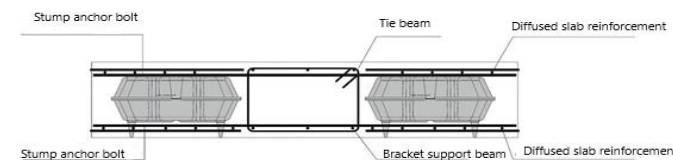

Figure 37 - construction detail of lightening with thick beam

The reinforcement in correspondence with the pillars must be suitably thickened, given the peaks of solicitation that occur in these areas. EC2, in the chapter 9.4 says:

"[...] it is recommended to place extradados reinforcements of area $0.5 A_t$ within a width equal to the sum of 0.125 times the widths of the panels taken on each side of the pillars. A_t represents the area of reinforcement necessary to support the entire negative moment acting on a width, equal to the sum of two half panels taken on each side of the pillar.

It is recommended that at internal pillars lower reinforcements (≥ 2 bars) are placed in each direction and that these reinforcements cross the pillar."

In correspondence with edge or corner pillars some geometric indications to be respected in order to transmit the bending moments from the plate to the pillar are made explicit, which translates into the definition of an effective width b_e , where the reinforcement perpendicular to the free board should be concentrated. Larger effective widths are presented in the British standard BS 8110, again for unbalanced moments in a direction perpendicular to the edge.

If the results are obtained from a finite element analysis, the negative moment at the columns or walls must be taken not at the support itself, as it is affected by the peak effect due to the discontinuity, but at a distance from the edge of the support which is usually approximable to the one thickness of the slab.



4. ON-SITE APPLICATION

4.1 PREPARATION OF THE FORMWORK

The slab lightened with elements of the **New Nautilus Evo** is executed in a similar way to a solid slab.

The casting needs a continuous horizontal formwork, possibly made with the use of prefabricated reinforced concrete slabs (*predalles*).

In this case, refer to the appropriate section.

The formwork can be of the traditional type, wood planks or plywood panels laid on a suitable mesh of H-beams made of wood as well or made of steel or aluminum.

It is strongly recommended, where possible, the use of specific formworks for the construction of slabs in-situ, with modular panels and dropped header supporting beams.

These systems maximize on-site productivity.



Figure 38 - formwork of cast-in-situ slab with modular metal formworks



Figure 39 - formwork of cast-in-situ slab with traditional wooden formwork and plywood panels



Figure 40 - formwork of cast-in-situ slab with modular wooden formworks

4.2 LAYING THE LOWER LAYER OF THE REINFORCEMENT

Once the lower formwork has been prepared, the spacers of the reinforcing bars and the basic reinforcement mesh of the lower layer must be placed. It is recommended to choose suitable spacers to let the concrete pass easily during the casting of the first layer. Usually there is a basic reinforcement and appropriate local refinements where necessary.

The basic reinforcement mesh can be laid by single crossed bars, by means of electro-welded mesh or by carpet, crossing two layers:

- Reinforcement by single bars: diameter $(d_x; d_y)$ and pitch $(e_x; e_y)$ according to the project, resting on the spacers suitable to guarantee the coverage (C) foreseen by project.

The minimum thickness of the lower slab (and consequently of the footing of lightning) in this case will be:

$$H_1 = C + d_x + d_y + \text{MAX} [d_x; d_y]$$

- Reinforcement with electrowelded mesh:

diameter $(d_x; d_y)$ and pitch $(e_x; e_y)$ according to the project, supported on the spacers suitable to guarantee the coverage (C) according to the project. The use of electrowelded meshes makes the installation of reinforcement faster, but note that the panels must be overlapped for at least $2e$ therefore in the coupling points of 4 panels the overlapping of the rebars occupies a space equal to $8(d_x + d_y)$ therefore, the minimum thickness of the lower slab (and consequently of the footing of the lightning) will be:

$$H_1 = C + 8(d_x + d_y) + \text{MAX} [d_x; d_y]$$

To avoid this inconvenience, it is suggested to use appropriate rationalized special type meshes.

- Carpet reinforcement: the carpet reinforcement is a special patent of the German company BAMTEC ©: these are rolls of rebars of variable pitch and diameter produced with numerical control with direct interface to the structural calculation program F.E.M. They are produced in such a way as to be able to provide the slab with the project strength once positioned.



Figure 41 – laying of the lower reinforcement mesh

4.3 ADDITIONAL REINFORCEMENT

Any additional reinforcement to the basic mesh can be made as follows:

- By varying pitch and diameter of the base reinforcement locally: in this case, check that the thickness of the lower slab (height of the footing) is adequate to ensure adequate covering of the bars in the area below the lightning.
- Adding bars in numbers and diameters suitable for obtaining the required moment of resistance inside the ribs that are created between one lightning and the other. The width of the rib must be such as to guarantee the space necessary to respect the reinforcement gap set by the regulations.

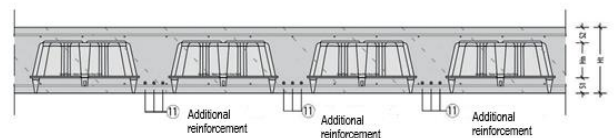

Figure 42 - example of additional reinforcement with loose bars and "single" lightning

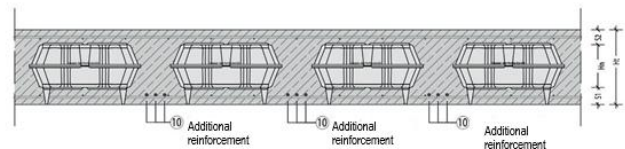

Figure 43 - example of additional reinforcement with loose bars and "double" lightning

- By laying prefabricated cages with reinforcing bars welded on open (U) brackets, crossed. This system allows to install at the same time any reinforcement, where necessary, by cutting. The width of the rib must be such as to guarantee the space necessary to respect the reinforcement gap set by the regulations.

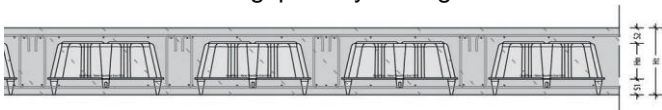

Figure 44 - example of additional prefabricated reinforcement and "single" type lightning

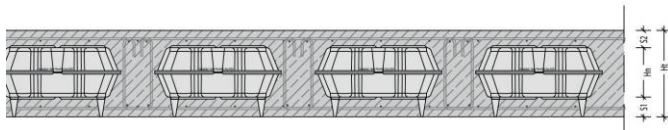

Figure 45 - example of additional prefabricated reinforcement and "double" type lightning



Figure 46 - layout of lightning



Figure 47 - layout of lightning

4.4 LAYING OF LIGHTENING

Once the lower layer of reinforcement is positioned, the lightning can be applied.

NOTE: in the case of DOUBLE lightning, the two half-shells "UP" and "DOWN" must be assembled before being laid, delivered on the construction site on separate pallets. The coupling occurs in a simple way through a "clip" joint.

For the installation of the lightning, follow the procedure below:

- Identify on the drawing supplied by GEOPLAST S.p.A. or in the project the starting point(s) of the installation, suitably listed.
- Place the lightning directly on the lower formwork.
- Tie the elements together using the appropriate spacing straps, taking care that the pin engages in correspondence with the number corresponding to the width of the rib planned in the project and shown in the sections of the drawings supplied by GEOPLAST S.p.A. or in the structural project.



Figure 48 - spacer strap for connecting the lightning

4.5 LAYING THE UPPER LAYER OF THE REINFORCEMENT

The basic reinforcement mesh could be placed for single-crossed bars, by means of electrowelded mesh or with a carpet, crossing two layers:

- Reinforcement for single bars: in diameter $(d_x; d_y)$ and pitch $(e_x; e_y)$ according to the project, resting on the adequate spacers to ensure coverage (C) provided by the project. The minimum thickness of the lower slab (and consequently of the footing of the lightning) in this case will be:

$$H_1 = C + d_x + 2d_y$$

- Reinforcement with electrowelded meshes in diameter $(d_x; d_y)$ and pitch $(e_x; e_y)$ according to the project, resting on the adequate spacers to ensure coverage (C) provided by the project. The use of electrowelded meshes makes the installation of reinforcement faster, but note that the panels must be overlapped for at least $2e$, therefore in the coupling points of 4 panels the overlapping of the rebars occupies a space equal to $8(d_x + d_y)$ therefore the minimum thickness of the lower slab (and consequently of the footing of the lightning) will be:

$$H_1 = C + 8(d_x + d_y) + \text{MAX}[d_x; d_y]$$

To avoid this inconvenience, it is suggested to use appropriate rationalized special type meshes.

- Carpet reinforcement: the carpet reinforcement is a special patent of the German company BAMTEC ©: these are rolls of rebars of variable pitch and diameter produced with numerical control with direct interface to the structural calculation program F.E.M. They are produced in such a way to provide the slab with the project resistance once they are positioned.



Figure 49 – placing of the upper reinforcement bars



Figure 50 - laying of the upper reinforcement bars

4.6 SPACERS

The electrowelded mesh up to 8 mm in diameter can be placed directly above the lightning, equipped with a special radial spacer.

Alternatively, specific trellis (one every 2-3 ribs) or the classic "OMEGA" trestles must be used.



Figure 51 - plastic and fiber cement spacers

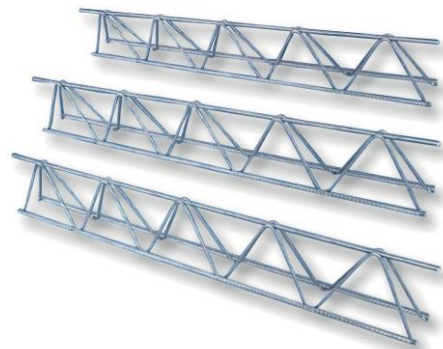

Figure 52 - plastic and fiber cement spacers

4.7 SHEAR AND PUNCHING REINFORCEMENT

Since these bars must anchor to the lower and upper mesh, they must be placed last.

Normally hooks or grapples are used, or special widened-head spikes equipped with special positioning brackets.

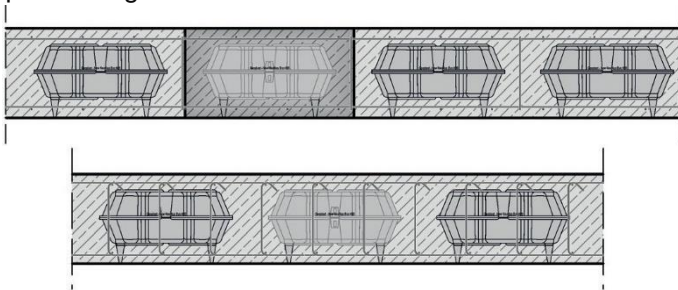
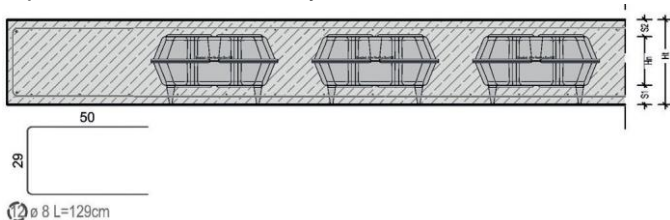

Figure 53 – shear reinforcement: longitudinal and transverse section

4.8 PERIMETER REINFORCEMENT

The perimeter strips of the lightweight slab must be left in solid concrete at a width at least equal to the thickness H of the slab.

Appropriate U-shaped bars designed to ensure the correct anchoring of the lower and upper layer bars must be provided, as indicated by the standards.



4.9 REQUIREMENTS FOR CONCRETE CASTING

The lightening materials tend to float in fresh concrete, which is why it is necessary to take some precautions during the casting, which will be carried out in two phases on the same day.

NOTE: under no circumstances should you puncture the lightening! The air leakage in fact eliminates the floatation but allows the concrete to penetrate the cavities, causing an increase in the weight of the structure not foreseen by the project. This could cause the structure to collapse.

Pour the concrete by directing the pump or bucket towards the ribs, in such a way as to exploit the pressure of the concrete and make it slide well below the lightening. Fill concrete up to a maximum of 4 cm beyond the height of the footing. If the formworks tend to rise, do not insist and continue further. Vibrate with care, visually checking that the concrete flows well below the lightening and checking that the concrete goes up through the cone, up to the level of the casting around the formwork (siphon principle). Continue in this way until the entire surface of the floor is complete.

To complete the casting, wait the necessary time until the concrete, even though it is still fresh, has started to set and has lost some of its fluidity.

An indicative time interval can be the following:

1. From 90' to 120' for the temperature higher than 20°C.
2. From 120' to 240' for the temperature lower than 20°C.

A practical indication of the correct state of maturation of the concrete consists in sticking a rebar into the casting and seeing if, once extracted, leaves a hole.



Figure 55 - cone correctly filled

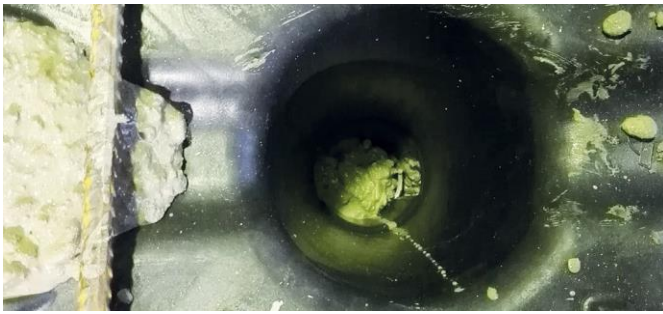

Figure 56 - cone not correctly filled, insist on vibration until reaching the situation of the previous figure



Figure 57 - the impression in the concrete indicates the right time to resume the casting

For casting surfaces over 500 m² it is not necessary to foresee interruptions of the pour, as the time required to prepare the first layer is normally greater than 120 '. For castings surfaces of less than 500 m², it is advisable to organize in anticipation of approximately 60 minutes of waiting for the second layer. If the second layer is carried out more than 4 hours with respect to the first, it is recommended to provide suitable construction bars as in correspondence with a cold junction.



Figure 58 - casting of the first layer

4.10 CONCRETE MIXDESIGN

For the correct mix of concrete design, rely on the concrete supplier technologist. Grain size, fluidity, additives must be chosen based on the thickness of the lower slab, diameter and pitch of the bars, environmental conditions in which the casting will take place.

For the casting of the first layer of concrete the ideal is to use a consistency class S5 and it is advisable to use concretes with a fluidity class lower than S4.

4.11 OPENING OF CAVITIES BEFORE CASTING

The lightened slab with New Nautilus Evo elements allows you to easily create holes and openings of any size. If the size of the hole can be inscribed within the lightening plan measurements and does not interrupt the ribs, no specific reinforcement will be required. For larger dimensions it is necessary to check the need for appropriate reinforcements during the design phase. In any case, a reinforcement of the type shown in the Figure below must be provided around these holes.



Figure 59 - preparation of cavities before casting

4.12 OPENING OF CAVITIES AFTER THE CONSTRUCTION OF THE SLAB

It will always be possible to open new holes in correspondence with the lightening, of maximum size that can be inscribed in the lightening plan measurements, as long as they do not cut the ribs. Larger cavities can also be made after casting the slab, taking care to perform a static check on the migration of forces on the edges of the opening due to the interruption of the continuity of the slab and possible restoration of its strength through special reinforcement. The slab must be suitably propped up if necessary.

The procedure is shown in the figures below.

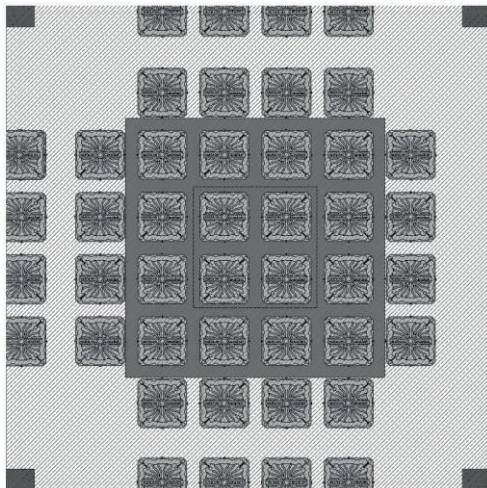

Figure 62 - in dark purple the opening to be made, in light purple the hole to be made

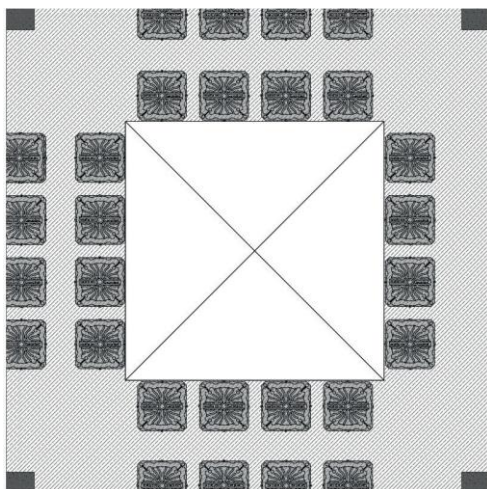

Figure 63 - temporary hole

4.13 USE OF DOWELS AND ANCHORING

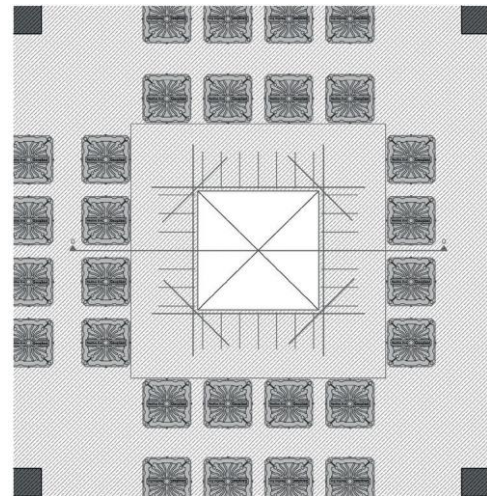

Figure 64 - final hole with reinforcement

It is possible to use dowels and anchors, both chemical (epoxy resins) and mechanical, to hang loads on the lower slab.

Refer to the technical data sheets of the suppliers (such as Hilti, Fisher, etc.) in order to correctly use (model, size, length etc.) the dowel according to the thickness of the lower / upper slab and the loads carried by it.



5 SPECIAL APPLICATIONS

5.1 PREFABRICATION

It is possible to create slabs cast-in-situ using semi-prefabricated slabs (predalles) as a formwork bottom. The main advantages of this solution are the lower formwork costs (especially in terms of time after the formwork has been struck). The use of this construction technique requires some additional precautions:

1. For lifting, the slabs need to have laterally two semi-ribs trellis. Since the **New Nautilus Evo** element has a width of 52 cm, it is only possible to use 240 cm wide slabs and 80 cm formwork interaxial spacing.
2. In the transverse direction it is possible to reduce the interaxial spacing to reduce the consumption of concrete, by shaping an anisotropic slab.
3. The reinforcement steel must necessarily be placed exclusively in the ribs or, at most, the first layer of the project already included in the plant can be foreseen within the prefabricated slabs.
4. Once placed together the slabs must be joined together with appropriately calculated seam bars along the perimeter.

Based on the above, the main disadvantage of this solution will be the greater consumption of concrete and steel compared to the equivalent solution totally cast-in-situ.

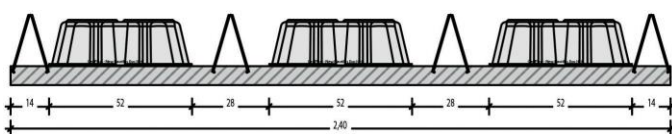
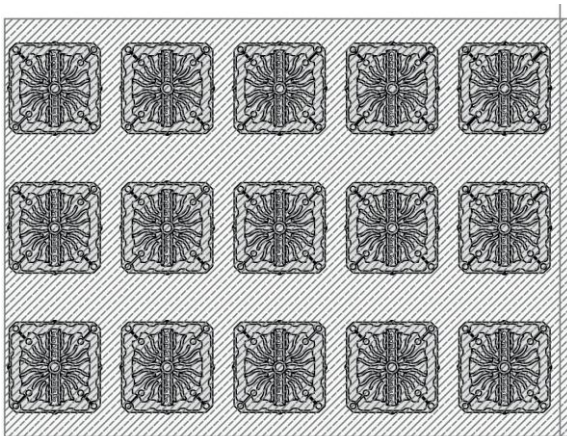

5.2 POST TENSIONING

It is possible to make post tension slabs lightened with **New Nautilus Evo** elements with post tension cables placed in one or two directions. This technology overcomes the intrinsic limits of span and load of the lightened slab system (slabs lightened with spans greater than 15-16 m go into shear and punching crisis, unless high-resistance concretes and very high reinforcement percentages are used), or to further reduce the thickness of the slab by pushing the advantages to the maximum due to the lightened structure. The cables can be placed directly in the ribs, or in massive bands suitably positioned and sized.



Figure 64 - post-tension cables on plate slab

5.3 THERMAL ACTIVATION OF THE MASSES

The last frontier of energy saving is the thermal activation of the masses.

This technology involves the embedding of pipes in the concrete structure in which water will flow at a suitable temperature. In this way the entire structure of the building contributes to air-conditioning the rooms, with considerable energy savings.

This type of technology is compatible with the New Nautilus Evo system and has been used successfully several times.

The structural design must obviously be flanked from the beginning with that of the plant.

If you are interested in this solution, we advise you to contact the market leaders, the Finnish company UPONOR:

<https://www.uponor.com/>



6. CERTIFICATIONS

6.1 BEHAVIOUR DURING FIRE LOAD AND FIRE RESISTANCE

The slab lightened with elements New Nautilus Evo has been tested on two occasions and in accordance with current European regulations.

The behavior under load from fire of the slab lightened with New Nautilus Evo elements is attested by the following documents:

- Test report n° CSI1890FR performed according to UNI EN 1365-2: 2002 and UNI EN 1363-1: 2012 issued by CSI BOLLATE (MI);
- Test report n° RS17-011 GEOPLAST - MC - RE according to the regulation NF - EN 1363-1 : 2013 - 03 NF - EN 1365 - 2 : 2014-12 issued by CSTB (France);
- Sizing abacus n° 26067076_AL1 for fire resistance issued by CSTB (France);

In particular, the tests carried out highlight the following:

1. The REI fire resistance, as for full slabs, is a function of the concrete cover, the number and diameter of the reinforcement, the total thickness of the slab and the width of the ribs;
2. It is possible to obtain any REI fire resistance class required by the standards, playing on the above parameters;
3. The presence of empty cavities does not worsen the conduction of heat inside the structure and does not generate excess pressures that cause the explosion of the slab.
4. The spalling of the concrete covers follows the behavior of traditional reinforced concrete structures.

Copies of test reports are available upon request by writing to: engineering@geoplast.it.

Sizing abacus for fire resistance is shown in the following pages

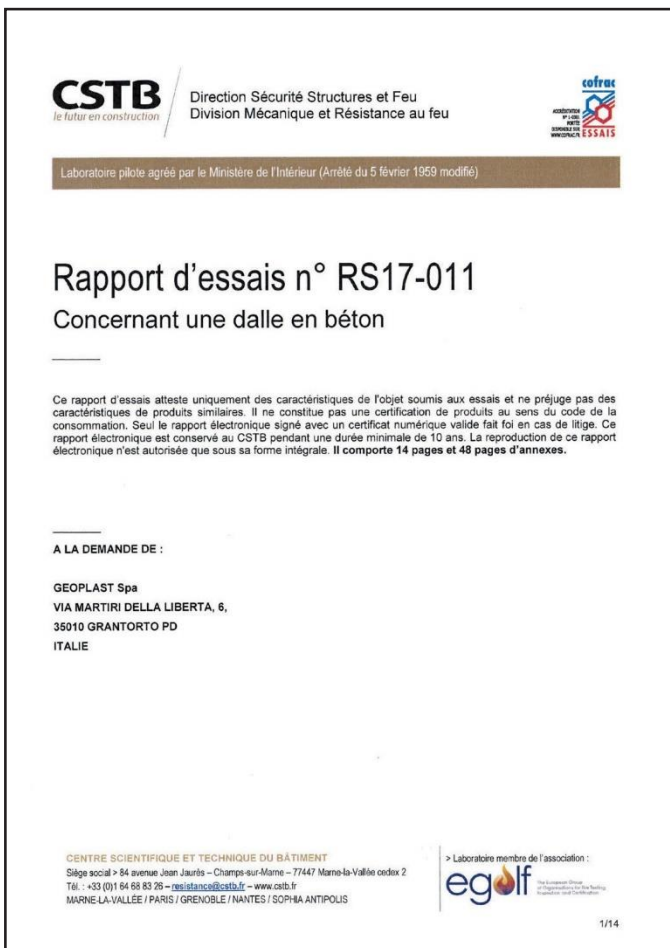

It is possible, as an alternative and in EU and non-EU countries where this procedure is allowed, to use analytical methods, such as finite element thermal analysis with the application of standardized temperature curves.

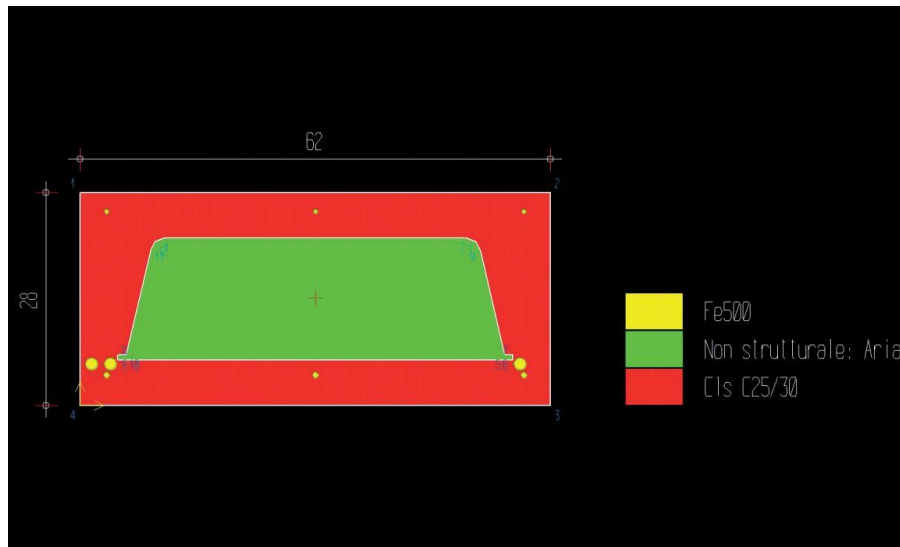

Figure 66 - modeling of the cross section of the slab (vacuum, concrete and steel)

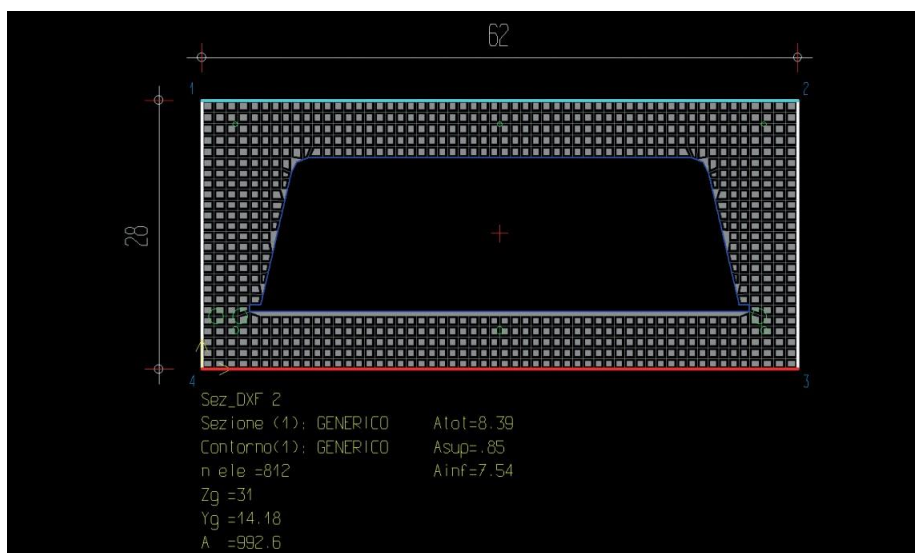

Figure 67 - model F.E.M. of the section

The analytical calculation of the section can be performed by our technical department upon request, after sending all the necessary data via email to: engineering@geoplast.it.

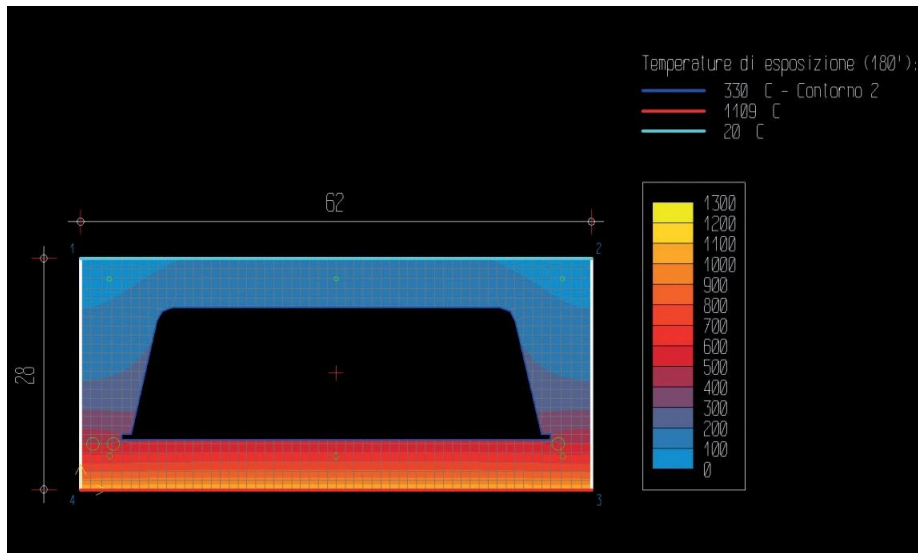

Figure 68 - calculation of thermal conduction over time for application of standardized temperature T ($^{\circ}\text{C}$, t) curve

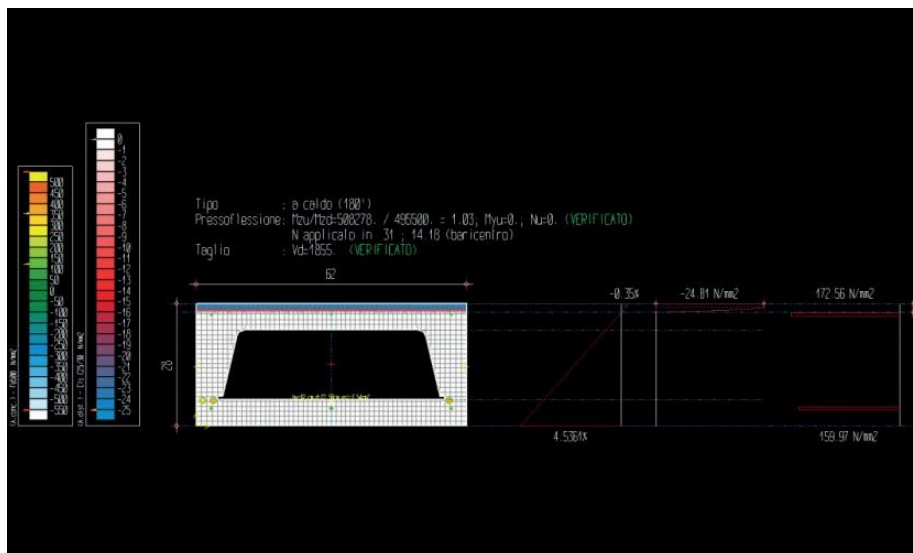

Figure 69 - Calculation of Moment and Shear resistant under fire

6.1.1 500°C ISOTHERM METHOD

The abacus obtained from the laboratory test and subsequent numerical analysis allows to carry out the hot verification of the section of the lightened slab with Nuovo Nautilus Evo in accordance with the method reported in Appendix B1 of UNI EN 1992 1-2: 2005, to which we refer for details.

It is basically a matter of reducing the resistant section neglecting the contribution of the concrete which is estimated to have a temperature above 500 ° C and reducing the strength of the reinforcing steel as a function of the verification temperature, then performing a verification of the section as if it was made cold.

Thanks to the abacus it is possible to have the temperature profile in the section for a given lower slab thickness and for a given fire duration (30-60-90-120-180 min.) with which it will be easy to obtain the appropriate reductions to operate on the section

CONFIGURATION 8-180

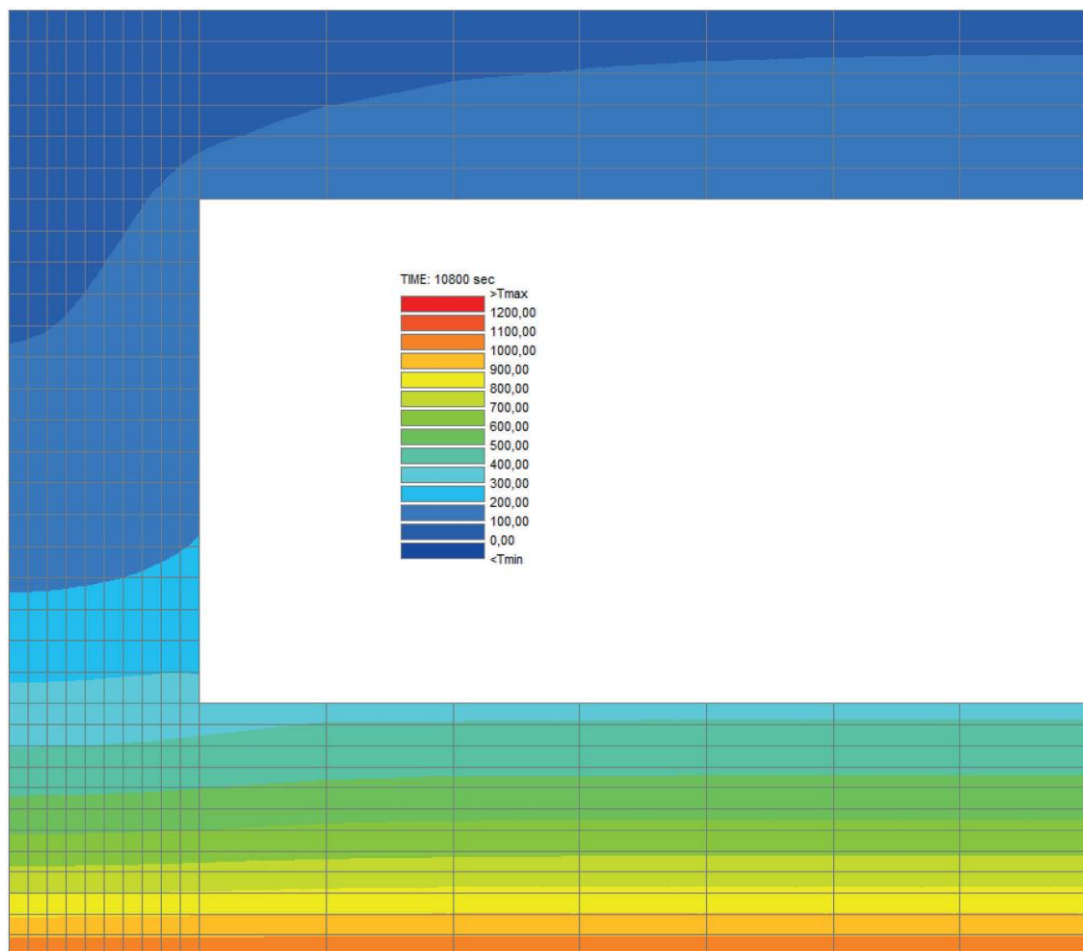

Figure 70 - isothermal configuration for S1 = 80 mm at 180 min

Y \ X (mm)	3	9	15	21	27	33	39	45	51	57	80	120	160	200	240	280	320
295,0	65	65	65	66	67	68	69	71	72	74	79	87	91	93	94	94	95
285,0	67	68	68	69	70	71	73	74	76	78	84	92	96	99	100	100	100
275,0	71	71	72	73	74	75	77	79	81	83	90	99	103	106	107	108	108
265,0	75	75	76	77	78	80	82	85	87	90	98	108	114	117	119	120	120
255,0	79	79	80	81	83	85	88	91	95	98	109	122	129	133	135	137	137
245,0	83	83	84	86	88	91	94	98	103	109	124	141	149	154	158	159	160
235,0	87	87	89	90	92	95	99	104	110	119	CONFIGURATION 8-180						
225,0	91	91	92	94	97	100	104	109	116	126							
215,0	94	95	96	98	100	103	108	114	121	131							
205,0	97	98	99	101	103	106	111	118	126	135							
195,0	100	100	102	103	106	110	115	121	130	140							
185,0	103	103	105	107	110	114	119	126	134	144							
175,0	107	108	109	111	115	119	124	131	140	150							
165,0	113	114	115	118	121	126	131	138	147	157							
155,0	122	123	124	127	130	135	141	148	156	166							
145,0	135	135	137	140	143	148	154	161	169	178							
135,0	152	153	154	157	160	165	170	177	184	193							
125,0	174	175	176	179	182	186	191	196	203	210							
115,0	201	201	203	205	208	211	215	219	224	230							
105,0	231	232	233	235	237	240	243	246	250	253							
95,0	266	267	268	269	271	274	276	279	281	281							
85,0	307	307	308	309	311	313	315	318	320	322							
76,7	344	345	345	347	348	350	353	355	358	362	377	389	389	391	391	391	392
70,0	378	379	379	381	382	384	387	389	392	396	409	422	423	425	425	425	425
63,3	416	416	417	418	420	422	424	427	430	433	445	458	460	462	462	462	462
56,7	458	458	459	460	462	463	466	468	471	474	485	497	501	502	503	503	503
50,0	505	505	506	507	508	510	512	514	517	520	530	542	546	547	548	548	548
43,3	557	557	558	559	560	562	564	566	568	571	580	591	596	597	597	598	598
36,7	616	616	616	617	619	620	622	624	626	628	636	647	651	653	653	653	653
30,0	682	682	682	683	684	686	687	689	691	692	700	709	713	715	715	715	715
23,3	756	756	757	757	758	759	761	762	764	765	771	779	783	784	785	785	785
16,7	840	840	840	841	841	842	843	844	845	847	852	858	861	862	862	862	862
10,0	933	933	933	933	934	935	935	936	937	938	941	945	947	948	948	948	948
3,3	1035	1035	1035	1035	1035	1036	1036	1036	1037	1037	1038	1040	1041	1041	1041	1041	1041

Figure 71 - abacus for section reduction and estimated iron temperatures - S1 = 80 mm at 180 min

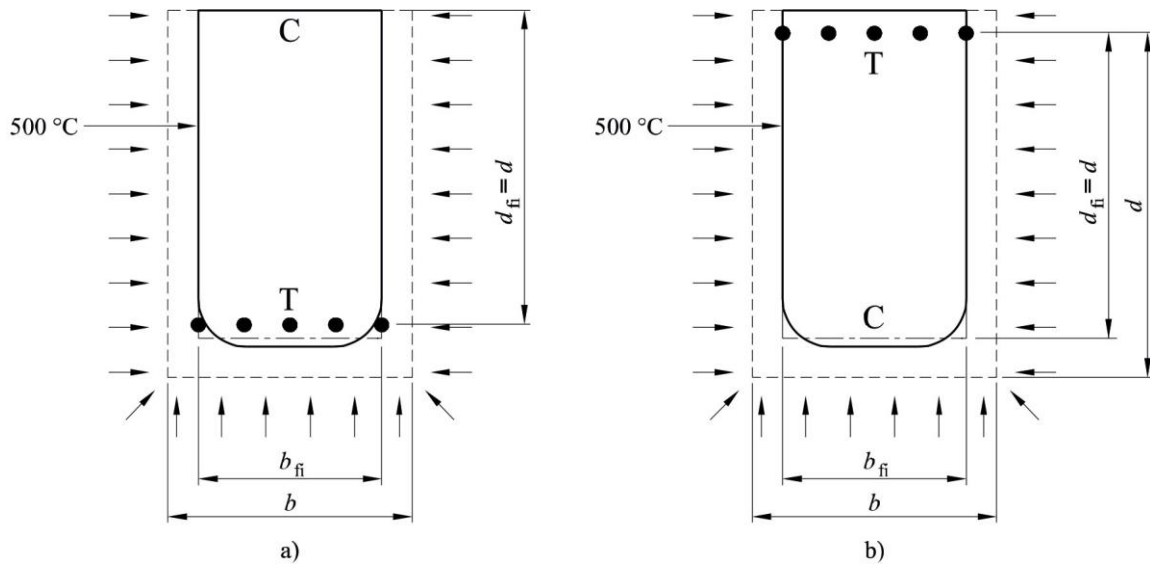

Figure 72 - reduction of the section subject to fire

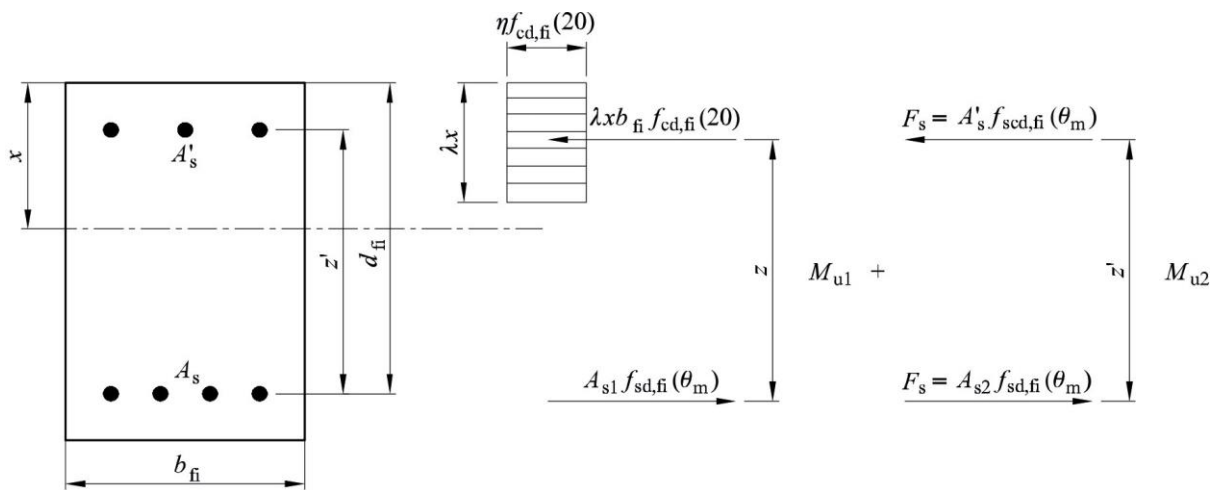

Figure 73 - static scheme for hot verification

For details, see UNI EN 1992 1-2: 2005, in particular the paragraphs:4.1

- 4.2
- 4.2.4
- APPENDIX B.1

6.2 ACOUSTIC BEHAVIOUR

For the calculation of the sound-insulating power R_w and of the trampling noise level L_n , w of the bare slab (without the contributions given by the finishes), it is necessary to refer to the full slab having the same weight, determining the surface mass m' in kg / m^2 .

To estimate the reference values, formulas of proven validity present in CEN, IEN Galileo Ferraris, DIN can be used.

Also available on request are some test reports carried out in situ on lightened slabs to the nude and with screed.

STUDIO ING. VINCENZO BACCAN
acustica industriale, architettonica e ambientale
Corso del Popolo, 161 - ROVIGO - tel. 0425.200040
info@studiobaccan.it

RAPPORTO DI PROVA N. 54/10

Data di emissione: 08/06/2010

Committente: Geoplast SpA
Via Martiri della Libertà, 6/8 - Grantorto (PD)

Tipo di prova: Misurazione in opera dell'isolamento acustico per via aerea tra ambienti secondo la norma tecnica UNI EN ISO 140-4 (2000)

Oggetto della prova: Solaio tra piano primo e piano terra presso edificio plurifamiliare in via Santocchia a Foligno (PG)

Identificazione della partizione: Solaio tra stanza letto al piano primo e stanza letto al piano terra

Caratteristiche costruttive:

- intonaco, cm 1
- soletta alleggerita con elementi Geoplast Nautilus, sp. cm 5+16+4
- cemento alleggerito per rasatura impianti, cm. 10-11
- materiale resiliente
- massetto autolivellante, cm 7-8

Superficie della partizione comune: 9,6 mq.

Volume dell'ambiente emittente: 28 mc.

Volume dell'ambiente ricevente: 28 mc.

Data di esecuzione della prova: 04/06/2010

La stratigrafia della partizione di prova è stata dichiarata dal Committente

Il presente rapporto di prova è composto da n. 6 pagine

ing. Vincenzo Baccan

Pagina
n. 1 di 6

RAPPORTO DI PROVA N. 54/10 Misurazione in opera dell'isolamento acustico per via aerea tra ambienti

Committente: Geoplast SpA - Via Martiri della Libertà, 6/8 - Grantorto (PD)
Data di emissione: 08/06/2010 **Data di prova:** 04/06/2010

Condizioni di prova: Le misure sono state eseguite ad edificio quasi completato. I fori di porte e finestre sono stati tamponati con pannelli in cartongesso. Come ambiente emittente è stata scelta la stanza al primo piano.

Strumentazione impiegata:

- Fonometro bicanale 01dB mod. Symphonie S/N 00882;
- Preamplificatore ACLAN mod. PRE 12H S/N 00881;
- Microfono GRAS mod. 40AE S/N 166999;
- Preamplificatore ACLAN mod. PRE 21A S/N 20312;
- Microfono Mikrotech Gefell mod. MK250 S/N 2888;
- Calibratore acustico ACLAN mod. CAL01 S/N 11038;
- Sorgente di rumore dodecaedrica Look Line mod. D301;

I certificati di taratura della catena di misura sono stati emessi in data 20/5/10 dal centro n. 164 (certificati n. F0516_10 e n. F0517_10) e in data 28/1/10 dal centro n. 164 (certificato n. C0361_10).

Dettagli sull'esecuzione di prova: Nella stanza emittente la sorgente sonora è stata posta in due posizioni distanti tra loro più di 1.4 m e distanti dalle pareti più di 0.5 m. Le due posizioni non individuavano alcun piano parallelo alle pareti. Per ogni posizione della sorgente sono state effettuate cinque misurazioni del livello sonoro per bande di 1/3 di ottava nell'ambiente emittente e cinque in quello ricevente. I punti di misura erano distanti tra loro almeno m 0,7, distanti dalle pareti almeno m 0,5 e distanti dalla sorgente almeno m 1. In totale sono state effettuate dieci misurazioni nell'ambiente emittente e dieci nell'ambiente ricevente, a due a due in contemporanea (lato emittente e lato ricevente) e ognuna con un tempo di integrazione sempre superiore a 10 secondi. Nella stanza ricevente sono stati misurati inoltre il livello del rumore di fondo e il tempo di riverberazione alle varie frequenze con il metodo della sorgente impulsiva, ripetendo due volte la prova in almeno tre punti.

Condizioni limite delle misurazioni: Nessuna.

STUDIO ING. VINCENZO BACCAN
acustica industriale, architettonica e ambientale
Corso del Popolo, 161 - ROVIGO
info@studiobaccan.it

ing. Vincenzo Baccan

Pagina
n. 2 di 6

6.3 THERMAL CONDUCTIVITY

To calculate the thermal conductivity of the slab lightened with New Nautilus Evo, it is necessary to calculate its thermal resistance. It appears to be the weighted average between the thermal resistance of a solid concrete slab and that of a cavity closed between two concrete slabs.

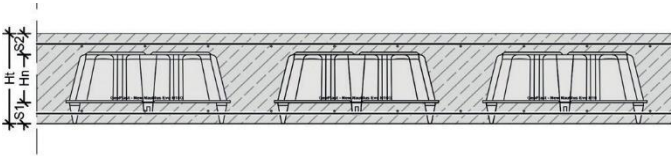

Figure 74 - typical profile of a lightened plate with New Nautilus Evo

The value is defined as thermal transmittance:

$$U = \frac{1}{R_{Tot}} \left[W / (m^2 \cdot K) \right]$$

In the case of a lightened slab with **New Nautilus Evo** elements, we will have two thermal resistances that work in parallel:

1.
$$R_{T1} = R_{si} + \frac{S_1}{\lambda_{cls}} + \frac{S_2}{\lambda_{cls}} + R_{int} + R_{se} \left[(m^2 \cdot K) / W \right]$$
2.
$$R_{T2} = R_{si} + \frac{H_t}{\lambda_{cls}} + R_{se} \left[(m^2 \cdot K) / W \right]$$

Where:

- ◆ R_{si} is the internal surface resistance equal to about 0.13;
- ◆ R_{se} is the external surface resistance equal to about 0.04;
- ◆ R_{int} is the thermal resistance of the air space within the cavity left by the formwork, equal to about 0.16 in favor of safety.

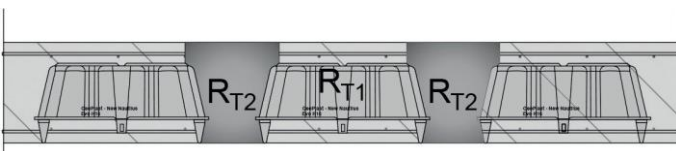

Figure 75 - overall surfaces of thermal resistances in parallel

La resistenza termica complessiva R_T è pari al contributo di ciascuna delle due resistenze, che sarà proporzionale alla superficie che ognuna occupa in pianta:

$$R_T = \frac{R_{T1} \cdot B^2 + R_{T2} \cdot (i^2 - B^2)}{i^2}$$

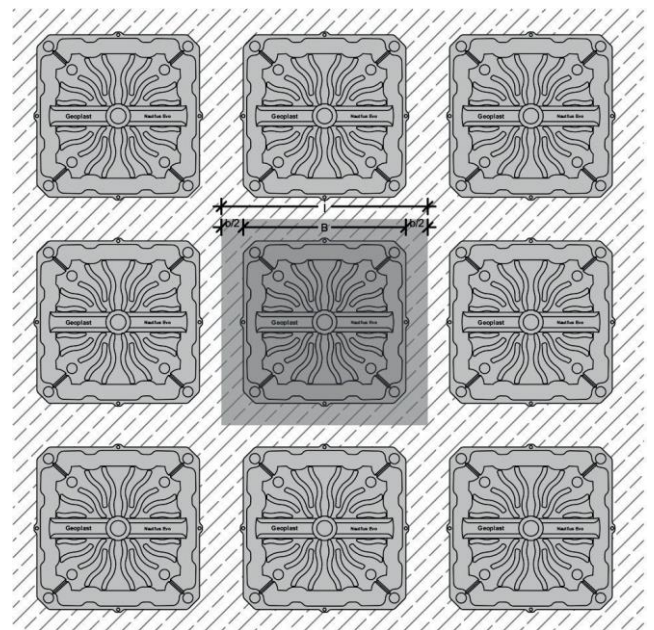

Figure 76 - overall surfaces of thermal resistances in parallel



7. PACKAGING AND LOGISTICS

7.1 NEW NAUTILUS EVO STANDARD PACKAGING CONDITIONS FOR LAND SHIPMENT

		NEW NAUTILUS EVO	
		SINGLE	DOUBLE
Elements per pallet	pcs	400	200
Dimensions per pallet	cm	100 X 120 X H max 250	
Weight of pallet	kg	560 max	

STANDARD LOAD FACTORS FOR DIFFERENT MEANS OF TRANSPORT

MEANS OF TRANSPORT	NUMBER OF PALLETS	DIMENSION OF MEANS
Truck	18	9,50 x 2,45 x h2,70 m
Truck + Trailer	14+14	Truck 7,70 x 2,45 x h2,70 m Trailer 7,70 x 2,45 x h2,70 m
Semitrailer	24	13,60 x 2,45 x h2,70 m
Container 20 ft.	24	5,90 x 2,35 x h2,39 m (door h2,28 m)
Container 40 ft.	22	12,03 x 2,35 x h2,39 m (door h2,28 m)
Container 40 ft. high cube	22	12,03 x 2,35 x h2,70 m (door h2,58 m)
Container 45 ft.	24	13,54 x 2,35 x h2,70 m (door h2,58 m)

Standard conditioning conditions for all models for complete pallets. The data shown here relates to complete pallets of a single model.



8. APPENDIX

8.1 KIRCHOFF SLAB

The following calculation hypotheses are considered:

- small thickness slab (less than 1/5 of the minimum effective span);
- small displacements and deformations (less than 1/5 of the slab thickness);
- transverse loads to the slab;
- decoupling between flexional and membranous problem (therefore symmetry of the slab with respect to the middle plane);
- negligible shear deformations;
- predominantly flexural regime (so segments originally orthogonal to the middle plane remain straight in the deformed configuration);
- linear elastic material, homogeneous and isotropic;
- negligible normal efforts on the middle plane;

therefore, the displacement components can be written, with reference to the Cartesian reference axes:

$$s_x(x, y, z) = -z \cdot \Phi_x(x, y)$$

$$s_y(x, y, z) = -z \cdot \Phi_y(x, y)$$

$$s_z(x, y, z) = w(x, y)$$

In the previous equations $w(x, y)$ is the displacement of the points of the middle plane in the direction z , $\Phi_x(x, y)$ and $\Phi_y(x, y)$ are the rotations of the tangent to the axis in the deformed position. On the basis of the hypothesis of a mainly flexural regime, flexural rotations can be written as derivatives of the transverse displacement of the middle plane.

$$\Phi_x = \frac{\partial w}{\partial x}$$

$$\Phi_y = \frac{\partial w}{\partial y}$$

Therefore, the deformation components will be:

$$\varepsilon_x = \frac{\partial s_x}{\partial x} = -z \cdot \frac{\partial^2 w}{\partial x^2}$$

$$\varepsilon_y = \frac{\partial s_y}{\partial y} = -z \cdot \frac{\partial^2 w}{\partial y^2}$$

$$\gamma_{xy} = \frac{\partial s_x}{\partial y} + \frac{\partial s_y}{\partial x} = -2z \cdot \frac{\partial^2 w}{\partial x \partial y}$$

The lightweight slabs represent a further evolution of the aforementioned structural system, with which not only important spans are obtainable, but it allows it with a saving in terms of consumption of concrete and steel, compared to a full slab solution.

In fact, in the analysis of the behavior of a reinforced concrete slab, the part of the section that is compressed is only a small portion with respect to the total thickness, the remaining part is not considered co-operating (given the poor performance of the concrete at traction), and it is necessary to consider it only in resisting shear stress, an action which is however very low away from the supports (area where no lightening is foreseen). Therefore, with the **New Nautilus EVO** elements we are going to reduce a virtually useless weight, managing to obtain a leaner slab, and greater possible spans.

8.2 STRESS REGIME

The stress regime is immediately deducible from the deformation state, once the linear elastic bond is introduced:

$$\sigma_x = \frac{E}{1 - \nu^2} \cdot (\varepsilon_x + \nu \cdot \varepsilon_y) = -z \cdot \frac{E}{1 - \nu^2} \cdot \left(\frac{\partial^2 w}{\partial x^2} + \nu \cdot \frac{\partial^2 w}{\partial y^2} \right)$$

$$\sigma_y = \frac{E}{1 - \nu^2} \cdot (\varepsilon_y + \nu \cdot \varepsilon_x) = -z \cdot \frac{E}{1 - \nu^2} \cdot \left(\frac{\partial^2 w}{\partial y^2} + \nu \cdot \frac{\partial^2 w}{\partial x^2} \right)$$

$$\tau_{xy} = \frac{E}{2 \cdot (1 + \nu)} \cdot \gamma_{xy} = -2z \cdot \frac{E}{2 \cdot (1 + \nu)} \cdot \frac{\partial^2 w}{\partial x \partial y} \cdot \frac{(1 - \nu)}{(1 - \nu)} =$$

$$= -z \cdot \frac{E}{(1 - \nu^2)} \cdot (1 - \nu) \cdot \frac{\partial^2 w}{\partial x \partial y}$$

8.3 INTERNAL ACTIONS

Analogously to what happens for a beam, also for the slab we operate by referring to components of the internal action.

The bending moment (per unit of length, measured along the middle plane) is defined as:

$$M_x = \int_{-h/2}^{h/2} \sigma_x \cdot z \, dz$$

$$M_y = \int_{-h/2}^{h/2} \sigma_y \cdot z \, dz$$

Dimensionally the bending moment will be a force, since

$$\left[\frac{F \cdot L}{L} \right]$$

The bending moment has a positive sign when a positive sign tension acts with a positive arm so positive M_x stretches the lower fibers. The previous integral gives as a result:

$$M_x = -\frac{E}{1-\nu^2} \cdot \left(\frac{\partial^2 w}{\partial x^2} + \nu \cdot \frac{\partial^2 w}{\partial y^2} \right) \int_{-h/2}^{h/2} z^2 \cdot dz =$$

$$= -\frac{E}{1-\nu^2} \cdot \frac{h^3}{12} \cdot \left(\frac{\partial^2 w}{\partial x^2} + \nu \cdot \frac{\partial^2 w}{\partial y^2} \right) = -D \cdot \left(\frac{\partial^2 w}{\partial x^2} + \nu \cdot \frac{\partial^2 w}{\partial y^2} \right)$$

In a similar way, the bending moment M_y is defined as:

$$M_y = \int_{-h/2}^{h/2} \sigma_y \cdot z \, dz = -D \cdot \left(\frac{\partial^2 w}{\partial y^2} + \nu \cdot \frac{\partial^2 w}{\partial x^2} \right)$$

In which is indicated as D flexural stiffness of the part of the slab of unit length. The shearing actions:

$$Q_x = \int_{-h/2}^{h/2} \tau_{xz} \, dz$$

$$Q_y = \int_{-h/2}^{h/2} \tau_{yz} \, dz$$

They cannot be expressed directly, as the shear deformations have been considered negligible, therefore we will have to go through equilibrium equations. However, the internal actions corresponding to the tangential tension $\tau_{xy} = \tau_{yx}$ distributed linearly along the thickness and with zero middle value remain to be

$$M_{yx} = \int_{-h/2}^{h/2} \tau_{yx} \cdot z \, dz = -D \cdot (1-\nu) \cdot \frac{\partial^2 w}{\partial x \partial y} = M_{xy}$$

$$M_{xy} = \int_{-h/2}^{h/2} \tau_{xy} \cdot z \, dz = -D \cdot (1-\nu) \cdot \frac{\partial^2 w}{\partial x \partial y}$$

defined.

Therefore, their resultant force (membrane type) will be zero, but will create torque:

8.4 EQUILIBRIUM EQUATIONS

In order to get the six unknowns ($w, Q_x, Q_y, M_x, M_y, M_{xy}$) it will be necessary to add three more equations to the three that link the moments to w .

To write these equations, consider an infinitesimal element subject to the action of a transverse load $p(x, y)$

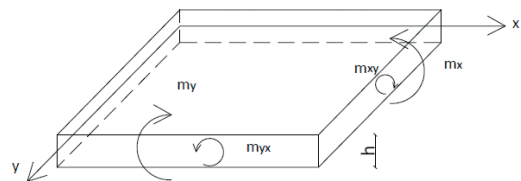

Figure 77 - moments acting on infinitesimal elements

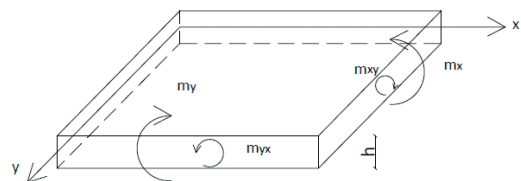

Figure 78 - shear agents on infinitesimal element

The equilibrium in rotation around the y is written (by omitting the infinitesimals of higher order, and simplifying the terms of opposite sign):

$$Q_x \cdot dx \cdot dy - \frac{\partial M_x}{\partial x} \cdot dx \cdot dy - \frac{\partial M_{xy}}{\partial y} \cdot dx \cdot dy = 0$$

$$Q_x = \frac{\partial M_x}{\partial x} + \frac{\partial M_{xy}}{\partial y}$$

Similarly, from the equilibrium to the rotation around the axis it results:

$$Q_y \cdot dx \cdot dy - \frac{\partial M_y}{\partial y} \cdot dx \cdot dy - \frac{\partial M_{yx}}{\partial x} \cdot dx \cdot dy = 0$$

$$Q_y = \frac{\partial M_y}{\partial y} + \frac{\partial M_{yx}}{\partial x}$$

Finally the equilibrium to the translation in the direction z :

$$p \cdot dx \cdot dy + \frac{\partial Q_x}{\partial x} \cdot dx \cdot dy + \frac{\partial Q_y}{\partial y} \cdot dx \cdot dy = 0$$

These equations allow writing in function of w of the shears and to derive the resolvent equation:

$$Q_x = \frac{\partial M_x}{\partial x} + \frac{\partial M_{xy}}{\partial y} = -D \cdot \left[\frac{\partial^3 w}{\partial x^3} + \nu \cdot \frac{\partial^3 w}{\partial y^2 \partial x} + (1 - \nu) \cdot \frac{\partial^3 w}{\partial y^2 \partial x} \right] = -D \cdot \left[\frac{\partial^3 w}{\partial x^3} + \frac{\partial^3 w}{\partial y^2 \partial x} \right]$$

$$Q_y = -D \cdot \left[\frac{\partial^3 w}{\partial y^3} + \frac{\partial^3 w}{\partial x^2 \partial y} \right]$$

Replacing in the equation of equilibrium to the translation in direction z

$$\frac{\partial^4 w}{\partial x^4} + 2 \cdot \frac{\partial^4 w}{\partial x^2 \partial y^2} + \frac{\partial^4 w}{\partial y^4} = \frac{p}{D}$$

This equation to the partial derivatives in x and in y is integrable only with approximate methods, such as series developments or discretization methods.

8.5 BOUNDARY CONDITIONS

A distinction can be made between kinematic boundary conditions and static boundary conditions. Starting with the kinematic boundary conditions, one can imagine being able to impose on a border $y = b$ for example at the edge, displacements or rotations:

$$w |_{y=b} = \bar{w}(x)$$

$$\left(\frac{\partial w}{\partial y} \right)_{y=b} = -\bar{\Phi}_{yz}(x)$$

While it is assigned, once you set rotation in the plane (z, x) :

$$\left(\frac{\partial w}{\partial x} \right)_{y=b} = -\bar{\Phi}_{xz}(x) = \frac{d\bar{w}(x)}{dx}$$

The independent kinematic conditions on the boundary are therefore only two. We then pass to the static boundary conditions; considering for example the boundary

$y = b$, there seem to be three quantities that can be fixed M_y, M_{xy}, Q_y . However, Kirchoff was able to demonstrate how M_{xy}, Q_y are connected, defining a sort of equivalent shear:

$$V_y = Q_y + \frac{\partial M_{xy}}{\partial x}$$

Which corresponds to the resultant of transversal agent forces (per unit of length), which can be written, replacing the previously developed formulas:

$$V_y = -D \cdot \left[\frac{\partial^3 w}{\partial x^3} + (2 - \nu) \frac{\partial^3 w}{\partial x^2 \partial y} \right]$$

This equation can be used both to impose a certain action on the boundary (as it can be free edge), and for the calculation of a constraining reaction distributed on the edge.

In the case of discontinuities, such as in the corners, concentrated forces emerge at the corners equal to:

$$R_i = \pm 2M_{xy}(x_i, y_i)$$

8.6 INTERNAL ACTIONS ON THE GENERIC SECTION

Let's assume we consider a generic section, whose normal n forms a generic angle β with axis x

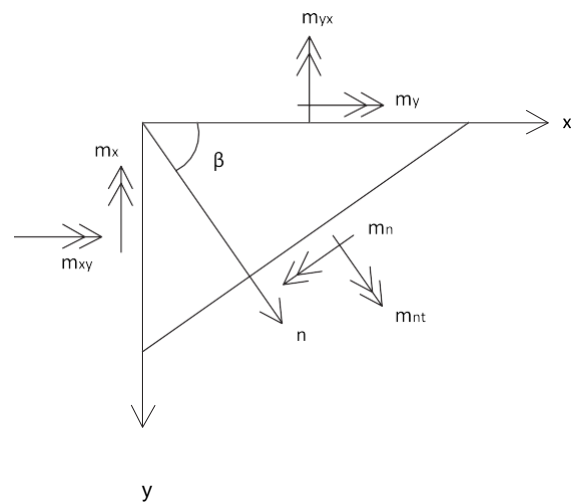

Considering that $dx = ds \cdot \sin \beta$ and $dy = ds \cdot \cos \beta$, first of all, we have a balance in the transverse direction z

$$Q_n = Q_x \cdot \cos \beta + Q_y \cdot \sin \beta$$

The equilibrium to the rotation around the tangent gives:

$$M_n = M_y \cdot \sin^2 \beta + 2 \cdot M_{xy} \cdot \sin \beta \cdot \cos \beta + M_x \cdot \cos^2 \beta$$

The balance in rotation around the normal, instead, leads to writing:

$$M_{nt} = (M_x - M_y) \cdot \sin \beta \cdot \cos \beta + M_{xy} \cdot (\sin^2 \beta - \cos^2 \beta)$$



Geoplast S.p.A.

Via Martiri della Libertà, 6/8
35010 Grantorto (PD) - Italy

Tel +39 049 9490289
Fax +39 049 9494028

Geoplast@Geoplastglobal.com

GeoplastGlobal.com
BuildingBeyondTogether.com



no. 110298

